

工业制冷控制元件

Industrial Refrigeration Control Components

选型图册

Atlas For Selecting Models

国际东阀®

International DOFUN

绿色制冷

Green refrigeration



Dofun

高端制冷阀门制造商

**Committed To Promoting
The Quality Process Of The Valve Industry**

致力于推进阀门行业的质量化进程

随着现代化生产的快速增长,产品类别和产品型号数量增长迅速,由此带来研发、生产、服务等成本的快速升高,在此背景下,东阀引入产品模块化设计DOFUN-CTP共享平台,有效降低成本、提高产品对市场的快速响应能力,同时生产出满足客户多样化需求的全球化产品。

DOFUN-CTP共享平台是一种高效的生产方式,通过模块化的应用,不仅可以共享部分阀门零部件,同时可在外形和连接尺寸等方面根据产品需求进行不同的定制。

统一规格的配件,有效降低库存成本。在不拆卸管道的前提下,通过功能模块的快速转换,实现不同的功能。简化选型过程,增加系统设计、安装维护的灵活性。

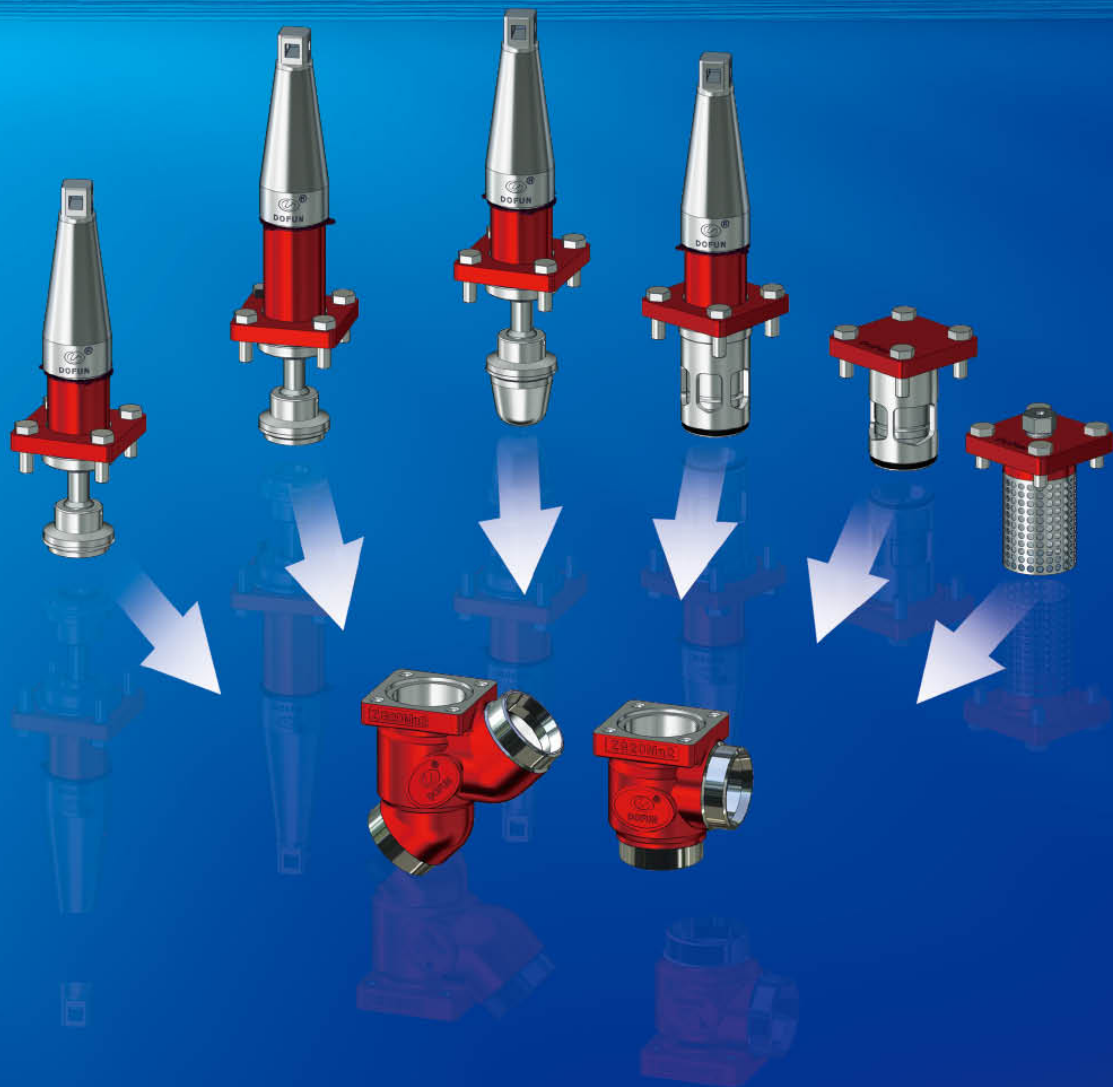

With the rapid growth of modern production, the number of product categories and models is growing rapidly, which leads to the rapid rise of R & D, production, service and other costs. In this context, Dongyuan introduces the dofun-ctp sharing platform of product modular design, which can effectively reduce costs, improve the rapid response ability of products to the market, and produce global products to meet the diversified needs of customers.

DOFUN-ctp sharing platform is an efficient production mode. Through modular application, it can not only share some valve parts, but also customize the shape and connection size according to the product requirements.

Uniform specifications of accessories, effectively reduce inventory costs. Under the premise of not dismantling the pipeline, different work forms can be realized by fast conversion of function modules. Simplify the selection process, increase the flexibility of system design, installation and maintenance.



公司简介 Company profile

山东东阀制冷科技有限公司坐落在历史文化底蕴丰富，风景优秀美丽的运河古都---聊城。

东阀注册资金5000万元，占地30余亩，并在烟台设有50余亩的工业园，拥有现代化厂房面积10000余平方米，并配备多条世界先进水平的阀门生产线及试验测试台。主营产品有截止阀、止回阀、截止止回阀、节流阀、过滤器、功能阀等，公司技术力量雄厚、生产设备精良、检测手段齐全，严格的体系管理，可靠的产品，以及不断的产品创新，使公司生产的各种材质的阀门产品广泛应用于制冷、石化、炼油、核电、化工、冶金、矿山、医药、食品、国防、军工等领域，在国内外具有很高的知名度和影响力，并取得了显著的成绩。

东阀一直秉承现代化企业先进的管理模式，依托高新技术优势，本着“安全节能增效，实现持续发展”的质量方针，遵循“务实，创新，追求无止境”的理念，坚持“质量为本，用户至上，竭诚服务”的宗旨，不懈努力，加倍奋斗，为国内外新老客户提供更优质的产品和服务。展望未来，我们将以更新、更高的全面服务立足本土，辐射全球营销网络体系，确保品牌向未来无限延伸，创造阀门新纪元，最终发展成为泵阀行业尖端制造工艺的生产商和领导者。

东阀的真正含义不只是实现心中所想，而是要把每一件东阀产品，都精雕细琢成金属艺术品，这将是我們为之奋斗不息的目标。

当世界上的人们还在这一步争分夺秒时，我们已经在下一步昂首启航！

东阀科技，只做更好的！

Shandong Dofun Refrigeration Technology Co.,Ltd, it is located in Liaocheng, the ancient capital of the canal with rich historical and cultural heritage and excellent scenery.

Dofun has a registered capital of 50 million yuan, covers an area of more than 30 acres, and has an industrial park of more than 50 acres in Yantai, with a modern plant area of more than 10,000 square meters, and is equipped with a number of world-advanced valve production lines and test benches. The main products are stop valves, check valves, stop check valves, regulating valves, filters, functional valves, etc. The company's strong technical force, sophisticated production equipment, complete testing methods, strict management system, reliable products, and continuous product innovation make the company's valve products of various materials widely used in refrigeration, petrochemical, oil refining, nuclear power, chemical engineering, metallurgy, mining, medicine, food, national defense, military industry and other fields. It has a high reputation and influence at domestic and foreign, and has achieved remarkable results.

Dofun has always been adhering to the advanced management model of a modern enterprise, relying on high-tech advantages, in line with the quality policy of "safety, energy saving and efficiency enhancement, achieving sustainable development", following the concept of "pragmatism, innovation, and endless pursuit", adhere to the tenet of "quality-oriented, customer first, and dedicated service", make unremitting efforts and redouble our efforts to provide better products and professional services to new and old customers at domestic and foreign. Looking to the future, we will base ourselves on the new and higher comprehensive service, radiate the global marketing network system, ensure the unlimited extension of the brand to the future, create a new era of valves, and eventually develop into a manufacturer and leader in the pump and valve industry.

The true meaning of Dofun is not only to realize what we think in mind, but to make every Dofun product into a metal artwork. This will be the goal for us to strive for.

While people in the world are still racing against time at this step, we are already heading for the next step!

Dofun, only do better!





功能阀系列简述 *Brief Introduction Of Function Valve Series* 01

压力调节阀系列 *Pressure Regulating Valve Series*

入口压力调节阀 *IPRV* 03
Inlet Pressure Regulating Valve IPRV Type

入口压力调节阀 (电磁强关) *IPRV-1C* 04
Inlet Pressure Regulating Valve (Solenoid Forced Close) IPRV-1C Type

入口压力调节阀 (电磁强开) *IPRV-1N* 05
Inlet Pressure Regulating Valve (Solenoid Forced Open) IPRV-1N Type

出口压力调节阀 *OPRV* 06
Outlet Pressure Regulating Valve OPRV Type

出口压力调节阀 (电磁强开) *OPRV-1N* 07
Outlet Pressure Regulating Valve(Solenoid Forced Open) OPRV-1N

压差调节阀 *DPAV* 08
Differential Pressure Regulating Valve DPAV Type

压差调节阀 (电磁强开) *DPAV-1N* 09
Differential Pressure Regulating Valve(Solenoid Forced Open) DPAV-1N Type

双级压力调节阀 *DPCV* 10
Dual Pressure Regulating Valve DPCV Type

双级压力压差调节阀 *DPCV-L* 11
Inlet & Differential Pressure Regulating Valve DPCV-L Type

气动阀系列 *Gas Powered Valve Series*

气动电磁阀 *DGPV* 12
Gas Powered Solenoid Valve DGPV Type

两步开启气动阀 (常闭) *DGPV-2C* 13
Two-Step Gas Powered Valve(Normally Close) DGPV-2C Type

电磁阀系列 *Solenoid Valve*

电磁阀 *DGSV* 14
Solenoid Valve DGSV Type

电磁阀 (铜) *DEVSC* 15
Solenoid Valve(Copper) DEVSC Type

电磁阀 (钢) *DEVS* 16
Solenoid Valve(Steel) DEVS Type

两步开启电磁阀 *DGSV-2C* 17
Two-Step Open Solenoid Valve DGSV-2C Type

手动阀PS60系列 **Manual Operation Valve PS60 Series**

截止阀 SVD	18
<i>Stop Valve SVD Type</i>	
节流阀 TVD	19
<i>Regulating Valve TVD Type</i>	
止回阀 CVD	20
<i>Check Valve CVD Type</i>	
截止止回阀 SCV	21
<i>Stop Check Valve SCV Type</i>	
过滤器 FVD	22
<i>Filter FVD Type</i>	

手动阀PN63系列 **Manual Operation Valve PN63 Series**

截止阀 SVD-H	23
<i>Stop Valve SVD-H Type</i>	
节流阀 TVD-H	24
<i>Regulating Valve TVD-H Type</i>	
止回阀 CVD-H	25
<i>Check Valve CVD-H Type</i>	
截止止回阀 SCV-H	26
<i>Stop Check Valve SCV-H Type</i>	
过滤器 FVD-H	27
<i>Filter FVD-H Type</i>	
不锈钢截止阀 SSVD	28
<i>Stainless Steel Stop Valve SSVD Type</i>	

组合阀DFCV系列 **Combination Valve DFCV Series** **29**

化霜三通阀DSV3系列 **Defrosting Three-way Valve DSV3 Series** **31**

油温调节阀OTRV系列 **Oil Temperature Regulating Valve OTRV Series** **32**

快速放油阀 QCV系列 **Quick Drain Valve QCV Series** **33**

电动阀DFMV系列 **Motor Valve DFMV Series** **34**

溢流阀OFD系列 **Overflow Valve OFD Series** **35**

液位开关LS50系列 **Liquid Switch LS50 Series** **36**

对夹止回阀NRVD系列 **Neck Flange Check Valve NRVD Series** **37**

筒式过滤器CFVD系列 **Cartridge Filter CFVD Series** **38**

小型截止阀SVS/SVA系列 **Small Stop Valve SVS/SVA Series** **39**

压力表阀PGV系列 **Pressure Gauge Valve PGV Series** **40**







三通截止阀DSV系列 **Double Stop Valve DSV Series** **41**





结构特点 **Structural Features** **42**

产品应用 **Product Application** **43**

功能阀系列 简述

Brief Introduction Of Function Valve Series

名称	外型	型号	功能	动作	应用
Product Name	Appearance	Model	Function	Action	Application
入口压力调节阀 Inlet Pressure Regulating Valve		IPRV DN25-DN125	控制入口压力 Control inlet pressure	入口压力高于设定值时开启。 It will be open when the inlet pressure is higher than the set value.	1、蒸发器压力控制 Evaporator pressure control 2、冷凝器压力控制 Condenser pressure control 3、任何入口压力控制 Any inlet pressure control
入口压力调节阀 (电磁强关) Inlet Pressure Regulating Valve (Solenoid Forced Close)		IPRV-1C DN25-DN125	控制入口压力或关闭调节阀 Control inlet pressure or close regulating valve	得电时按照预设压力值调节，断电时关闭阀门。 It is adjusted according to the preset pressure value when the power is on, and closes the valve when the power is off.	1、温度、压力控制时开启 Turn on when temperature and pressure are controlled 2、除霜时关闭 Turn off when defrosting
入口压力调节阀 (电磁强开) Inlet Pressure Regulating Valve (Solenoid Forced Open)		IPRV-1N DN25-DN125	控制入口压力或全开调节阀 Control inlet pressure or fully open regulating valve	得电时全开阀门，断电时按照预设压力值调节。 It will make the valve open fully when the power is on, and adjust according to the preset pressure value when the power is off.	1、最大冷却时全开 It will fully open when fully cooled. 2、除霜时调节 Adjust during defrosting 3、温度、压力控制时调节 Adjust during temperature and pressure control
出口压力调节阀 Outlet Pressure Regulating Valve		OPRV DN25-DN65	控制出口压力 Control outlet pressure	按照预设压力值调节出口压力，出口压力下降时打开。 It can adjust the outlet pressure according to the preset pressure value and open it when the outlet pressure drops.	1、曲轴箱压力调节 Crankcase pressure adjustment 2、热气旁通，低压加载 Hot gas by pass, low pressure loading 3、储液器压力控制 Reservoir pressure control
出口压力调节阀 (电磁强开) Outlet Pressure Regulating Valve (Solenoid Forced Open)		OPRV-1N DN25-DN65	控制出口压力或全开调节阀 Control outlet pressure or fully open regulating valve	得电时全开阀门，断电时按照预设压力值调节。 It will make the valve open fully when the power is on, and adjust according to the preset pressure value when the power is off.	1、曲轴箱压力调节 Crankcase pressure adjustment 2、热气旁通，低压加载 Hot gas by pass, low pressure loading 3、储液器压力控制 Reservoir pressure control
压差调节阀 Differential Pressure Regulating Valve		DPAV DN25-DN125	控制入口与出口的压力差 Control the pressure difference between inlet and outlet	压力低于设定值时调节压差 It can adjust the pressure difference when the pressure is lower than the set value	1、供液泵泄压调节 Liquid supply pump pressure relief regulation 2、减小介质管路压力 Reduce pressure of media line

名称	外型	型号	功能	动作	应用
Product Name	Appearance	Model	Function	Action	Application
压差调节阀 (电磁强开) Differential Pressure Regulating Valve (Solenoid Forced Open)		DPAV-1N DN25-DN125	控制入口与出口的压力差 Control the pressure difference between inlet and outlet	压力低于设定值时调节压差,得电时全开阀门 It can adjust the pressure difference when the pressure is lower than the set value. It will make the valve open fully when the power is on.	1、供液泵泄压调节 Liquid supply pump pressure relief regulation 2、减小介质管路压力 Reduce pressure of media line 3、最大压力、流量全开 Maximum pressure; Flow fully open
双级压力压差调节阀 Inlet & Differential Pressure Regulating Valve		DPCV-L DN40-DN125	压力压差双级压力控制 Pressure differential and Inlet pressure control	双电磁阀压力控制 Individual solenoid valve for different pressure control	1、冷凝压力控制 Condensing pressure control 2、除霜时调节 Adjust when defrosting
气动电磁阀 Gas Powered Valve		DGPV DN25-DN125	常开型, 动作后全关闭 Normally open type, fully closed after action	外部高压气源、电磁阀控制活塞切断管路 Externally connected with high-pressure air source; Solenoid Valve controls the piston to cut off pipeline	1、低压回气管路 Low pressure return air pipeline 2、热气融霜 Hot air melting frost
两步开启气动阀 (常闭) Two-Step Gas Powered Valve (Normally Closed)		DGPV-2C DN40-DN125	两步式开启阀门 Two-step type open valve	外部高压气源控制 第一步得电时打开阀10% 第二步全开 Externally connected with high-pressure air source. Step 1: open the valve 10% when power is on. Step 2: Fully open.	热气融霜 Hot air melting frost
电磁阀 Solenoid Valve		DGSV DN40-DN125	打开或关闭系统 Open or close system	得电全开或关闭阀门 It can open fully or close when the power on.	1、吸气管路 Suction pipeline 2、液态管路 Liquid pipeline 3、热气融霜 Hot air melting frost
两步开启电磁阀 Two-step Open Solenoid Valve		DGSV-2C DN40-DN125	两步式开启 Two-step type Open	内部高压气源控制断电紧急关闭 Internal high-pressure air source control. Emergency shut down when the power is off.	1、压缩机排气 Compressor exhaust 2、需要紧急切断管路 There is need to cut off the pipeline urgently

1、技术参数 Technical Parameter

- 公称通径: DN25-DN125
Nominal Diameter: DN25-DN125
- 压力调整范围: A:0~10.3bar D:5.2~19.3bar
Pressure Adjustment Range: A:0~10.3bar D:5.2~19.3bar
- 公称压力: 2.8MPa
Nominal Pressure: 2.8MPa
- 适用介质: R12,R22,R502,R134a,R404a,R507,R717等制冷剂。
Applicable Medium: R12,R22,R502,R134a,R404a,R507,R717 and other refrigerants.
- 适用温度: -46°C~+120°C
Applicable Temperature: -46 °C ~ + 120 °C
- 本产品具备手动开启功能, 保证系统可靠运行。
The product has a manual opening function to ensure the reliable operation of the system.
- 连接方式: 两端法兰
Connection Method: flanges at both ends.

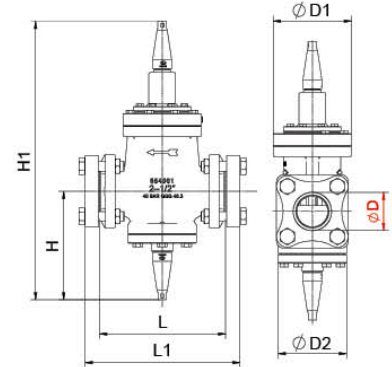

2、说明 Instruction

IPRV入口压力调节阀用于蒸发器、冷凝器压力控制, 其它任何入口压力控制, 确保阀前压力低于导阀压力设定值。

The IPRV is a pressure regulating valve for pressure control of evaporator, condenser pressure and other refrigeration system inlet pressure, to ensure that the pressure before the valve is lower than the pilot valve pressure setting value.

3、订货 Order Goods

- 订货时需指定型号、设定压力值、压力调整范围
Please tell us the model, set pressure value and pressure adjustment range you want when ordering.
- 例:IPRV50-D, 9bar
E.g.:IPRV50-D, 9bar
表示: DN50入口压力调节阀,
It is means DN50 Inlet Pressure Regulating Valve,
出厂设定压力: 9bar
Factory Setting Pressure: 9bar
压力调整范围5.2~19.3bar
Pressure Adjustment Range 5.2~19.3bar
如不指定设定压力, 压力调整范围: 出厂默认10bar, 压力调整范围D
If the set pressure is not specified, the Pressure Adjustment Range is factory default 10bar, Pressure Adjustment Range is D.

入口压力调节阀 Inlet Pressure Regulating Valve								
型号 Model	通径 Nominal Diameter (DN)	尺寸 (mm)Size (mm)						
		φD	φD1	φD2	L	L1	H	H1
IPRV	25	34	117	108	194	231	210	498
	32	40	117	108	194	231	210	498
	40	47	144	140	246	301	234	569
	50	59	144	140	246	301	234	569
	65	78	159	140	252	316	234	585
	80	91	176	170	311	376	337	702
	100	110	222	195	359	433	355	760
	125	135	257	235	394	471	361	748

1、技术参数 Technical Parameter

- ◆ 公称通径: DN25-DN125
Nominal Diameter: DN25-DN125
- ◆ 压力调整范围: A:0~10.3bar D:5.2~19.3bar
Pressure Adjustment Range: A:0~10.3bar D:5.2~19.3bar
- ◆ 公称压力: 2.8MPa
Nominal Pressure: 2.8MPa
- ◆ 适用介质: R12,R22,R502,R134a,R404a,R507,R717等制冷剂。
Applicable Medium: R12,R22,R502,R134a,R404a,R507,R717 and other refrigerants.
- ◆ 适用温度: -46°C~+120°C
Applicable Temperature: -46 °C ~ + 120 °C
- ◆ 连接方式: 两端法兰
Connection Method: flanges at both ends.

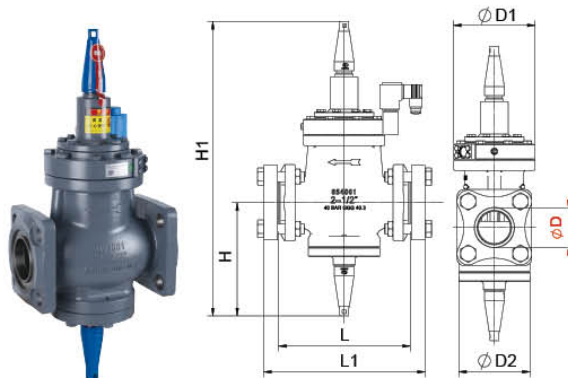

2、说明 Instruction

IPRV-1C入口压力调节阀(电磁强关)和IPRV入口压力调节阀一样,控制入口压力,带有强制关闭功能,得电时调节,失电时关闭。得电时,当入口压力超过导阀的设定压力时,主阀开启,压力低于设定值时主阀关闭;失电时压力导阀进气口关闭,主阀关闭。适用于温度控制时开启、除霜时关闭

The IPRV-1C is the same as the IPRV inlet pressure regulating valve, which controls the inlet pressure and has a function of forced shut-off. It is adjusted when power is turned on and closed when power is turned off. When power is on: the main valve opens when the inlet pressure exceeds the set pressure of the pilot valve, and the main valve closes when the pressure is lower than the set value; when the power is off, inlet of the pressure pilot valve closes and the main valve closes. Suitable for opening during temperature control and closing during defrosting.

3、订货 Order Goods

- ◆ 订货时需指定型号、设定压力值、压力调整范围
Please tell us the model, set pressure value and pressure adjustment range you want when ordering.
- ◆ 例:IPRV40-1CD, 9bar
E.g.:IPRV40-1CD, 9bar
表示: DN40入口压力调节阀(电磁强关),
It means DN40 Inlet Pressure Regulating Valve(Solenoid Forced Close),

压力调节范围5.2~19.3bar
Pressure Adjustment Range 5.2~19.3bar
出厂设定压力: 9bar
Factory Setting Pressure: 9bar
如不指定设定压力,压力调整范围: 出厂默认10bar,压力调整范围D
If the set pressure is not specified, the Pressure Adjustment Range is factory default 10bar, Pressure Adjustment Range is D.

入口压力调节阀(电磁强关) Inlet Pressure Regulating Valve (Solenoid Forced Close)								
型号 Model	通径 Nominal Diameter (DN)	尺寸(mm)Size (mm)						
		φD	φD1	φD2	L	L1	H	H1
IPRV-1C	25	34	117	108	194	231	210	498
	32	40	117	108	194	231	210	498
	40	47	144	140	246	301	234	569
	50	59	144	140	246	301	234	569
	65	78	159	140	252	316	234	585
	80	91	176	170	311	376	337	702
	100	110	222	195	359	433	355	760
	125	135	257	235	394	471	361	748

1、技术参数 Technical Parameter

- ◆ 公称通径: DN25-DN125
Nominal Diameter: DN25-DN125
- ◆ 压力调整范围: A:0~10.3bar D:5.2~19.3bar
Pressure Adjustment Range: A:0~10.3bar D:5.2~19.3bar
- ◆ 公称压力: 2.8MPa
Nominal Pressure: 2.8MPa
- ◆ 适用介质: R12,R22,R502,R134a,R404a,R507,R717等制冷剂。
Applicable Medium: R12,R22,R502,R134a,R404a,R507,R717 and other refrigerants.
- ◆ 适用温度: -46°C~+120°C
Applicable Temperature: -46 °C ~ + 120 °C
- ◆ 本产品具备手动开启功能, 保证系统可靠运行。
The product has a manual opening function to ensure the reliable operation of the system.
- ◆ 连接方式: 两端法兰
Connection Method: flanges at both ends.

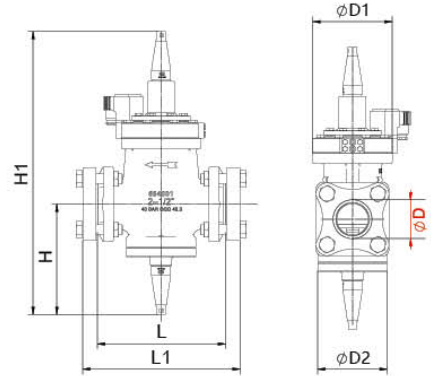

2、说明 Instruction

IPRV-1N入口压力调节阀(电磁强开)和IPRV入口压力调节阀一样,控制入口压力。带有强制打开功能,失电时调节,得电时全开。失电时,当入口压力超过导阀的设定压力时,主阀开启,压力低于设定值时主阀关闭;得电时,介质直接通过电磁阀进入活塞上部,主阀全部打开。适用于最大冷却时全开,除霜和温度控制时调节。

The IPRV-1N is same as the IPRV Inlet Pressure Regulating Valve, which controls the inlet pressure. It is with forced opening function, it can adjust when the power is off, and fully opened when power is on. Power is off, the main valve opens when the inlet pressure exceeds the set pressure of the pilot valve. The main valve closes when the pressure is lower than the set value; When power is on, the medium directly enters the upper part of the piston through the Solenoid Valve, and the main valve is fully opened. It is suitable for full opening during maximum cooling and adjustment during defrosting and temperature control.

3、订货 Order Goods

- ◆ 订货时需指定型号、设定压力值。
Please tell us the model ,set pressure value and pressure adjustment range you want when ordering.
- ◆ 例:IPRV40-1ND, 9bar
E.g.:IPRV40-1ND, 9bar
表示: DN40入口压力调节阀(电磁强开) ,
It is means DN40 Inlet Pressure Regulating Valve (Solenoid Forced Open)

压力调节范围5.2~19.3bar

Pressure Adjustment Range 5.2~19.3bar

出厂设定压力: 9bar

Factory Setting Pressure: 9bar

如不指定设定压力, 压力调整范围: 出厂默认10bar, 压力调整范围D

If the set pressure is not specified, the Pressure Adjustment Range is factory default 10bar, Pressure Adjustment Range is D.

入口压力调节阀 (电磁强开) Inlet Pressure Regulating Valve (Solenoid Forced Open)								
型号 Model	通径 Nominal Diameter (DN)	尺寸 (mm)Size (mm)						
		φD	φD1	φD2	L	L1	H	H1
IPRV-1N	25	34	117	108	194	231	210	498
	32	40	117	108	194	231	210	498
	40	47	144	140	246	301	234	569
	50	59	144	140	246	301	234	569
	65	78	159	140	252	316	234	585
	80	91	176	170	311	376	337	702
	100	110	222	195	359	433	355	760
	125	135	257	235	394	471	361	748

1、技术参数 Technical Parameter

- 公称通径: DN25-DN65
Nominal Diameter: DN25-DN65
- 压力调整范围: A:0~10.3bar D:5.2~19.3bar
Pressure Adjustment Range: A:0~10.3bar D:5.2~19.3bar
- 公称压力: 2.8MPa
Nominal Pressure: 2.8MPa
- 适用介质: R12,R22,R502,R134a,R404a,R507,R717等制冷剂。
Applicable Medium: R12,R22,R502,R134a,R404a,R507,R717 and other refrigerants.
- 适用温度: -46°C~+120°C
Applicable Temperature: -46 °C ~ + 120 °C
- 本产品具备手动开启功能, 保证系统可靠运行。
The product has a manual opening function to ensure the reliable operation of the system.
- 连接方式: 两端法兰
Connection Method: flanges at both ends.

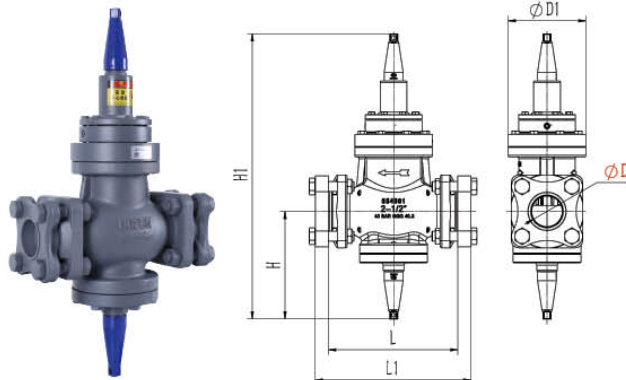

2、说明 Instruction

OPRV出口压力调节阀适用于控制出口压力, 用于避免出口压力低于预定的设定值, 根据预设压力值调节出口压力, 出口压力下降时打开, 来控制冷凝器压力或作为曲轴箱压力调节阀控制吸气压力。

The OPRV is suitable for controlling the outlet pressure. It is used to prevent the outlet pressure from being lower than the predetermined set value. The outlet pressure is adjusted according to the preset pressure value. When the outlet pressure drops, it opens to control the condenser pressure or as the crankcase pressure regulating valve to control the suction pressure.

3、订货 Order Goods

- 订货时需指定型号、设定压力值、压力调节范围
Please tell us the model ,set pressure value and pressure adjustment range you want when ordering.
- 例:OPRV40-A, 4bar
E.g.:OPRV40-A, 4bar
表示: DN40出口压力调节阀,
It is means DN40 Outlet Pressure Regulating Valve,
压力调节范围A: 0~10.3bar
Pressure Adjustment Range A: 0~10.3bar
出厂设定压力: 7bar
Factory Setting Pressure: 7bar
如不指定压力, 压力调节范围: 出厂默认7bar, 压力调整范围A
If the set pressure is not specified, the Pressure Adjustment Range is factory default 7bar, Pressure Adjustment Range is A.

出口压力调节阀 Outlet Pressure Regulating Valve								
型号 Model	通径 Nominal Diameter (DN)	尺寸 (mm)Size (mm)						
		φD	φD1	φD2	L	L1	H	H1
OPRV	25	34	117	108	194	231	210	545
	32	40	117	108	194	231	210	545
	40	47	144	140	246	301	234	595
	50	59	144	140	246	301	234	595
	65	78	159	140	252	316	234	610

1、技术参数 Technical Parameter

- ◆ 公称通径: DN25-DN65
Nominal diameter: DN25-DN65
- ◆ 压力调整范围: A:0~10.3bar D:5.2~19.3bar
Pressure Adjustment Range: A:0~10.3bar D:5.2~19.3bar
- ◆ 公称压力: 2.8MPa
Nominal Pressure: 2.8MPa
- ◆ 适用介质: R12,R22,R502,R134a,R404a,R507,R717等制冷剂。
Applicable Medium:R12,R22,R502,R134a,R404a,R507,R717 and other refrigerants.
- ◆ 适用温度: -46°C~+120°C
Applicable Temperature: -46 °C ~ + 120 °C
- ◆ 本产品具备手动开启功能, 保证系统可靠运行。
The product has a manual start function to ensure the reliable operation of the system.
- ◆ 连接方式: 两端法兰
Connection Method: flanges at both ends.

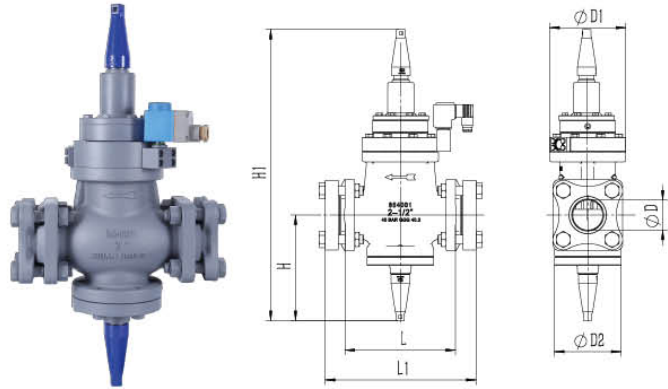

2、说明 Instruction

OPRV出口压力调节阀(电磁强开) 适用于控制出口压力, 用于出口压力低于预定的设定值, 根据预设压力值调节出口压力, 出口压力下降时打开, 来控制冷凝器压力或作为曲轴箱压力调节阀控制吸气压力, 电磁阀得电时, 全开阀门。

The OPRV-1N is suitable for controlling the outlet pressure. It is used to adjust the outlet pressure according to the preset pressure value when the outlet pressure is lower than the preset value. When the outlet pressure drops, it opens to control the condenser pressure or act as The crankcase pressure regulating valve controls the suction pressure, and when the solenoid valve is energized, the valve is fully opened.

3、订货 Order Goods

- ◆ 订货时需指定型号、设定压力值、压力调节范围
Please tell us the model, set pressure value and pressure adjustment range you want when ordering.
- ◆ 例:OPRV40-1NA, 4bar
E.g.:OPRV40-1NA 4bar
表示: DN40出口压力调节阀(电磁强开),
It is means DN40 Outlet Pressure Regulating Valve(Solenoid Forced Open)
压力调节范围A: 0~10.3bar
Pressure Adjustment Range A:0~10.3bar

出厂设定压力: 7bar

Factory Setting Pressure:7bar

如不指定压力, 压力调整范围: 出厂默认7bar, 压力调整范围D

If the set pressure is not specified, the Pressure Adjustment Range is factory default 4bar, Pressure Adjustment Range is D.

出口压力调节阀 (电磁强开) Outlet Pressure Regulating Valve(Solenoid Forced Open)								
型号 Model	通径 Nominal Diameter (DN)	尺寸 (mm)Size (mm)						
		φD	φD1	φD2	L	L1	H	H1
OPRV-1N	25	34	117	108	194	231	210	555
	32	40	117	108	194	231	210	555
	40	47	144	140	246	301	234	605
	50	59	144	140	246	301	234	605
	65	78	159	140	252	316	234	622

1、技术参数 Technical Parameter

- ◆ 公称通径: DN25-DN125
Nominal Diameter: DN25-DN125
- ◆ 压力调整范围: A:0~10.3bar D:5.2~19.3bar
Pressure Adjustment Range: A:0~10.3bar D:5.2~19.3bar
- ◆ 公称压力: 2.8MPa
Nominal Pressure: 2.8MPa
- ◆ 适用介质: R12,R22,R502,R134a,R404a,R507,R717等制冷剂。
Applicable Medium:R12,R22,R502,R134a,R404a,R507,R717 and other refrigerants.
- ◆ 适用温度: -46°C~+120°C
Applicable Temperature: -46 °C ~ + 120 °C
- ◆ 本产品具备手动开启功能, 保证系统可靠运行。
The product has a manual opening function to ensure the reliable operation of the system.
- ◆ 连接方式: 两端法兰
Connection Method: flanges at both ends.

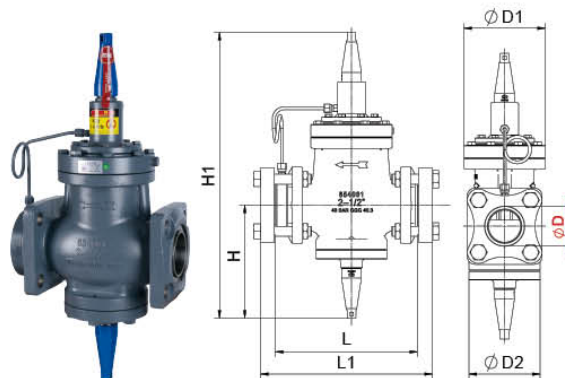

2、说明 Instruction

DPAV压差调节阀当进口、出口压力差低于设定的压力值时, 调节压差, 根据设定压差值开启或关闭, 适用于供液泵泄压调节或可以减少介质管路压力。
The DPAV adjusts the pressure difference when the inlet and outlet pressure difference is lower than the set pressure value, and opens or closes according to the set pressure difference value. It is suitable for the pressure adjustment of the liquid supply pump or can reduce the pressure of the medium line.

3、订货 Order Goods

- ◆ 订货时需指定型号、设定压力值、压力调整范围
Please tell us the model ,set pressure value and pressure adjustment range you want when ordering.
- ◆ 例:DPAV40-A, 4bar
E.g.:DPAV40-A, 4bar
表示: DN40压差调节阀,
It is means DN40 Differential Pressure Regulating Valve

压力调节范围0~10.3bar
Pressure Adjustment Range 0~10.3bar
出厂设定压力: 4bar
Factory setting pressure: 4bar
如不指定压力, 压力调整范围: 出厂默认4bar, 压力调整范围A
If the set pressure is not specified, the Pressure Adjustment Range is factory default 4bar, Pressure Adjustment Range is A

压差调节阀 Differential Pressure Regulating Valve								
型号 Model	通径 Nominal Diameter (DN)	尺寸 (mm)Size (mm)						
		φD	φD1	φD2	L	L1	H	H1
DPAV	25	34	117	108	194	252	210	498
	32	40	117	108	194	252	210	498
	40	47	144	140	274	325	234	580
	50	59	144	140	274	325	234	580
	65	78	159	140	277	356	234	595
	80	91	176	170	336	397	337	628
	100	110	222	195	384	475	355	684
	125	135	257	235	418	500	410	763

1、技术参数 Technical Parameter

- 公称通径: DN25-DN125
Nominal Diameter: DN25-DN125
- 压力调整范围: A:0~10.3bar D:5.2~19.3bar
Pressure Adjustment Range: A: 0~10.3bar D: 5.2~19.3bar
- 公称压力: 2.8 MPa
Nominal Pressure: 2.8MPa
- 适用介质: R12,R22,R502,R134a,R404a,R507,R717等制冷剂。
Applicable Medium: R12,R22,R502, R134a,R404a,R507,R717 and other refrigerants.
- 适用温度: -46°C~+120°C
Applicable Temperature: -46 °C ~ + 120 °C
- 本产品具备手动开启功能, 保证系统可靠运行。
The product has a manual opening function to ensure the reliable operation of the system.
- 连接方式: 两端法兰
Connection Method: flanges at both ends.

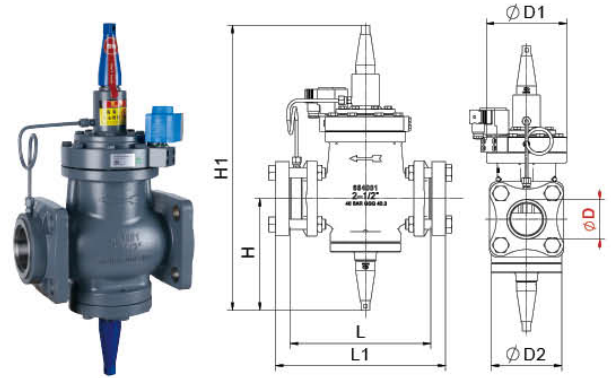

2、说明 Instruction

DPAV-1N压差调节阀(电磁全开)失电时调节,进口、出口压力差低于设定的压力值时,调节压差。适用于供液泵泄压调节或可以减少介质管路压力。得电时,全开主阀,使出口得到更大的流量和压力。

The DPAV-1N which adjust when power is off, which adjust pressure difference when the inlet and outlet pressure difference is lower than the set pressure value. It is suitable for the relief pressure adjustment of the liquid supply pump or can reduce the pressure of the medium pipeline. When the power is on, the main valve opens fully to make the outlet get a larger flow and pressure.

3、订货 Order Goods

- 订货时需指定型号、设定压力值
Please tell us the model and set pressure value you want when ordering.
- 例: DPAV40-1NA, 4bar
E.g.: DPAV40-1NA, 4bar
表示: DN40压差调节阀(电磁全开),
It means DN40 Differential Pressure Regulating Valve(Solenoid Fully Open)
压力调节范围0~10.3bar
Pressure Adjustment Range 0~10.3bar

出厂设定压力: 4bar

Factory Setting Pressure: 4bar

如不指定压力, 压力调整范围: 出厂默认4bar, 压力调整范围A

If the set pressure is not specified, the Pressure Adjustment Range is factory default 4bar, Pressure Adjustment Range is A.

压差调节阀 (电磁全开) Differential Pressure Regulating Valve (Solenoid Forced Open)

型号 Model	通径 Nominal Diameter (DN)	尺寸 (mm) Size (mm)						
		φD	φD1	φD2	L	L1	H	H1
DPAV-1N	25	34	117	108	214	251	210	508
	32	40	117	108	214	251	210	508
	40	47	144	140	268	325	234	575
	50	59	144	140	268	325	234	575
	65	78	159	140	277	356	234	585
	80	91	176	170	335	400	337	702
	100	110	222	195	384	455	355	760
	125	135	257	235	418	500	365	750

1、技术参数 Technical Parameters

- ◆ 公称通径：DN40-DN125
Nominal Diameter: DN40-DN125
- ◆ 压力调整范围：A:0 ~ 10.3bar D:5.2 ~ 19.3bar
Pressure adjustment range: A:0 ~ 10.3bar D:5.2 ~ 19.3bar
- ◆ 公称压力：2.8MPa
Nominal pressure: 2.8MPa
- ◆ 适用介质：R12,R22,R502,R134a,R404a,R507,R717 等制冷剂。
Applicable Medium: R12,R22,R502, R134a,R404a,R507,R717 and other refrigerants.
- ◆ 适用温度：-46℃ ~ +120℃
Applicable Temperature: -46℃ ~ +120℃
- ◆ 本产品具备手动开启功能，保证系统可靠运行。
This product has the function of manual opening to ensure the reliable operation of the system
- ◆ 连接方式：两端法兰
Connection Method: flanges at both ends.

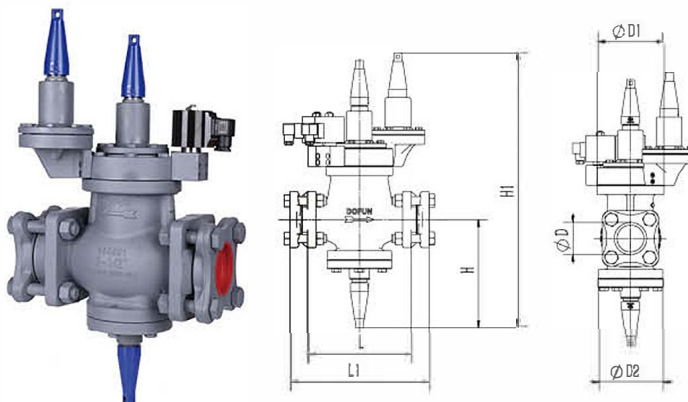

2、说明 Instruction

本产品用于蒸发器压力控制、冷凝器力控制及其他制冷系统入口压力控制的双压力入口调节阀，压力调节阀由一个主阀和两个调节导阀组成，调节导阀能够调节两个不同的设定压力。

The DPCV is used for dual pressure inlet regulating valves for evaporator pressure control, condenser force control and other refrigeration system inlet pressure control. The pressure regulating valve is composed of a main valve and two regulating pilot valves. The regulating pilot valve can regulate two different set pressure.

低压侧默认 7bar Low pressure side default 7bar

高压侧，默认 10bar High Pressure side default 10bar

3、订货 Order Goods

- ◆ 指明型号，如 DPCV50 表示 DN50 双级入口压力调节阀
Specify the model, such as DPCV50 means DN50 two-stage inlet pressure regulating valve

电磁阀 Solenoid Valve	A	B	阀门动作 Valve Action
状态 Status	打开 Open	关闭 Close	低压侧调节，打开或关闭阀门 Low-pressure side regulation, opening or closing the valve
	关闭 Close	打开 Open	高压侧调节，打开或关闭阀门 High pressure side regulation, opening or closing the valve

双级压力调节阀 Two-Stage Pressure Regulating Valve								
型号 Model	通径 Nominal Diameter (DN)	尺寸 (mm) Size (mm)						
		φD	φD1	φD2	L	L1	H	H1
DPCV	40	47	144	140	248.5	300.5	222	580
	50	59	144	140	248.5	300.5	222	580
	65	78	159	140	252	331	222	595
	80	91	176	170	311	389	273	628
	100	110	222	195	359	450	292	684
	125	135	257	235	393.6	475.6	410	763

1、技术参数 Technical Parameters

- ◆ 公称通径：DN40-DN125
Nominal diameter: DN40-DN125
- ◆ 压力调整范围：
压差侧：0 ~ 10.3bar 压力侧：5.2 ~ 19.3ba
Pressure Adjustment Range:
Differential Pressure side: 0 ~ 10.3bar Pressure Side: 5.2 ~ 19.3bar
- ◆ 公称压力：2.8MPa
Nominal Pressure: 2.8MPa
- ◆ 适用介质：R12,R22,R502,R134a,R404a,R507,R717 等制冷剂。
Applicable Medium: R12,R22,R502, R134a,R404a,R507,R717 and other refrigerants.
- ◆ 适用温度：-46℃ ~ +120℃
Applicable Temperature: -46℃ ~ +120℃
- ◆ 本产品具备手动开启功能，保证系统可靠运行。
This product has the function of manual opening to ensure the reliable operation of the system.
- ◆ 连接方式：两端法兰
Connection Method: flanges at both ends.

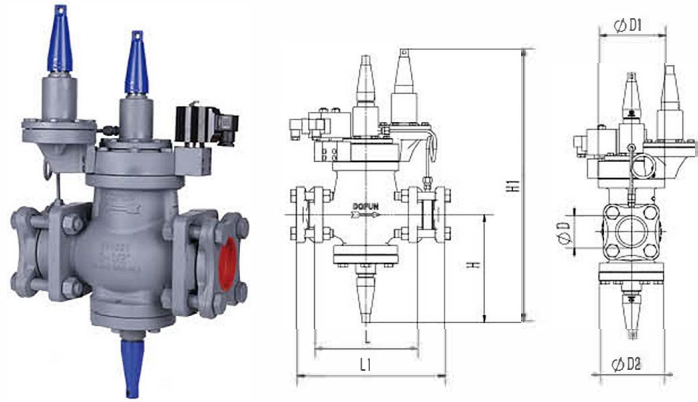

2、说明 Instruction

本产品用于蒸发器压力控制、冷凝器力控制及其他制冷系统入口压力控制、供液压差等。

The DPCV-L is used for evaporator pressure control, condenser force control and other refrigeration system inlet pressure control, supply hydraulic pressure difference, etc.

压力调节阀由一个主阀和两个调节导阀组成，调节导阀能够调节两个不同的设定压力。

The pressure regulating valve consists of a main valve and two regulating pilot valves, which can regulate two different set pressures.

压差侧默认 4bar Differential pressure side default 4bar

压力侧默认 10bar Pressure side default 10bar

注意：电磁阀 A 和 B 不能同时打开

Please Pay Attention: Solenoid valves A and B cannot be opened at the same time.

3、订货 Order Goods

- ◆ DPCV-L50, 表示 DN50 双级压力压差阀
Specify the model, such as DPCV50 means DN50 two-stage inlet pressure regulating valve

电磁阀 Solenoid Valve	A	B	阀门动作 Valve Action
状态 Status	打开 Open	关闭 Close	压差侧调节，打开或关闭阀门 Differential side regulation, opening or closing the valve
	关闭 Close	打开 Open	压力侧调节，打开或关闭阀门 Pressure side regulation, opening or closing the valve

双级压力调节阀 Two-Stage Pressure Differential Regulating Valve

型号 Model	通径 Nominal Diameter (DN)	尺寸 (mm) Size (mm)						
		φD	φD1	φD2	L	L1	H	H1
DPCV-L	40	47	144	140	274	325	234	580
	50	59	144	140	274	325	234	580
	65	78	159	140	277	356	234	595
	80	91	176	170	336	397	337	628
	100	110	222	195	384	475	355	684
	125	135	257	235	418	500	410	763

1、技术参数 Technical Parameter

- ◆ 公称通径: DN25-DN125
Nominal Diameter: DN25-DN125
- ◆ 公称压力: 2.8MPa
Nominal Pressure: 2.8MPa
- ◆ 适用介质: R12,R22,R502,R134a,R404a,R507,R717 等制冷剂。
Applicable Medium: R12, R22,R502,R134a, R404a, R507, R717 and other refrigerants.
- ◆ 适用温度: -46°C ~ +120°C
Applicable Temperature: -46 °C ~ + 120 °C
- ◆ 连接方式: 两端法兰
Connection Method: flanges at both ends.

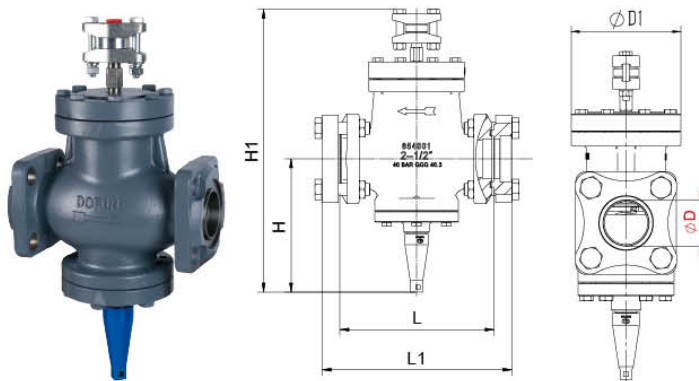

2、说明 Instruction

DGPV 气动截止阀是一种需要外接气源（高压制冷剂气体）的气动常开电磁阀，适用于制冷系统的回气低压管道、热气融霜系统。
The DGPV is a pneumatic normally open Solenoid Valve which need to connect an external gas source(high-pressure refrigerant gas). It is suitable for the return air low-pressure pipeline of the refrigeration system and the hot gas defrosting system.

3、订货 Order Goods

- ◆ 指定型号
Please tell us the model you want when ordering.
- ◆ 例 :DGPV40
E.g.: DGPV40
- ◆ DN40 气动电磁阀
It is means DN40Pneumatic Solenoid Valve

气动电磁阀 Gas Powered Solenoid Valve							
型号 Model	通径 Nominal Diameter (DN)	尺寸 (mm)Size (mm)					
		φD	φD1	L	L1	H	H1
DGPV	25	34	117	194	231	210	400
	32	40	117	194	231	210	400
	40	47	144	246	301	234	452
	50	59	144	246	301	234	452
	65	78	160	252	316	234	466
	80	91	176	311	376	337	500
	100	110	222	359	433	355	553
	125	135	257	394	471	361	635
上部过滤器接口尺寸 18 Upper filter port Size 18							

1、技术参数 Technical Parameter

- 公称通径: DN32-125
Nominal Diameter: DN32-125
- 公称压力: 2.8MPa
Nominal Pressure: 2.8MPa
- 适用介质: R12,R22,R502,R134a,R404a,R507,R717等制冷剂。
Applicable Medium: R12, R22, R502, R134a, R404a, R507, R717 and other refrigerants.
- 适用温度: -46°C ~ +120°C
Applicable Temperature: -46 °C ~ + 120 °C
- 连接方式: 两端法兰
Connection Method: flanges at both ends.

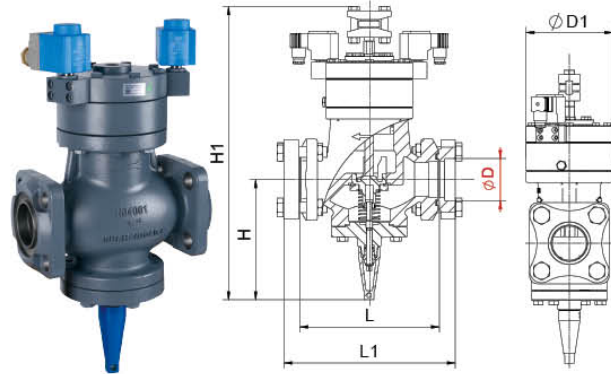

2、说明 Instruction

两步开启气动阀 (常闭) 开启状态有2个模块电磁导阀依次控制, 使其处于关闭、10%开启、100%开启3种状态。实际使用中可根据实际情况调整3种状态的时间间隔, 从而实现理想的运行效果, 适用于热气除霜系统的供热管路。

The DGPV-2C its open state is controlled by two module solenoid pilot valves in sequence, making it in three states: closed, 10% open, 100% open. In actual use, the time interval of the three states can be adjusted according to the actual situation, so as to achieve the ideal operating effect, which is suitable for the heating gas pipeline of the hot gas defrosting system.

3、订货 Order Goods

- 需指定型号
Please tell us the model you want when ordering.
- 例: DGPV50-2C
E.g.: DGPV50-2C
表示: DN50两步开启气动阀 (常闭)
It is means DN50 Two-step Open Pneumatic Valve(Normally Closed)

两步开启气动阀 (常闭) Two-step Gas Powered Valve (Normally Close)

型号 Model	通径 Nominal Diameter (DN)	尺寸 (mm) Size (mm)					
		φD	φD1	L	L1	H	H1
DGPV-2C	32	40	117	194	231	210	477
	40	47	144	246	301	234	534
	50	59	144	246	301	234	534
	65	78	160	252	316	234	556
	80	91	176	311	376	337	672
	100	110	222	361	433	355	730
	125	135	257	394	471	361	720

1、技术参数 Technical Parameter

- ◆ 公称通径: DN10-DN65
Nominal Diameter: DN10-DN65
- ◆ 公称压力: 2.8MPa
Nominal Pressure: 2.8MPa
- ◆ 适用介质: R12,R22,R502,R134a,R404a,R507,R717等制冷剂。
Applicable Medium: R12,R22,R502,R134a,R404a,R507,R717 and other refrigerants.
- ◆ 适用温度: -46°C ~ +120°C
Applicable Temperature: -46 °C ~ + 120 °C
- ◆ DN10-DN20阀体配带过滤器
DN10-DN20 valve housing with filter
- ◆ 连接方式: 两端法兰
Connection Method: flanges at both ends.

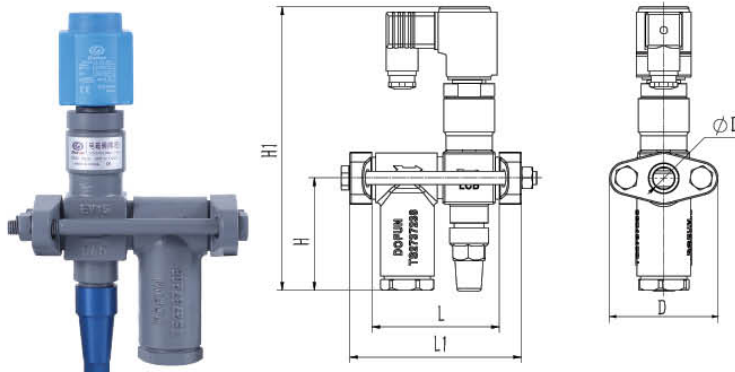

2、说明 Instruction

DGSV电磁阀主要应用于吸气管路、液体管路及热气融霜管路上, 得电打开, 失电关闭。

The DGSV is mainly used in the suction line, liquid line and hot gas defrosting line, it will open when power is on, and close when power is off.

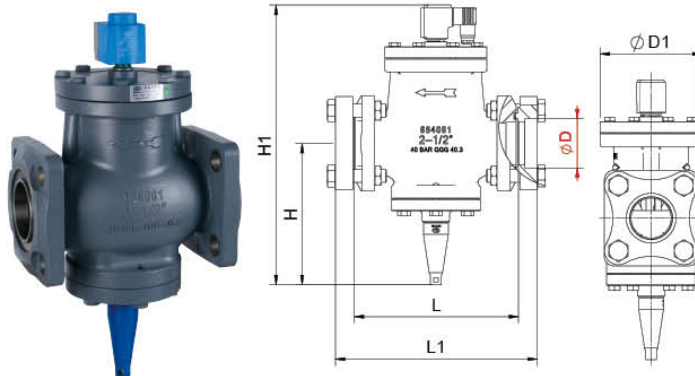

3、订货 Order Goods

- ◆ 需指定型号
Please tell us the model you want when ordering.
- ◆ 例: DGSV50
E.g.:DGSV50
表示DN50电磁阀
It is means DN50 Solenoid Valve

电磁阀 Solenoid Valve							
型号 Model	通径 Nominal Diameter (DN)	尺寸 (mm)Size (mm)					
		φD	D1	L	L1	H	H1
DGSV	10	19	81	95	128	84	212
	15	23	81	95	128	84	212
	20	29	95	142	168	92	250
	25	40	117	194	231	205	384
	32	40	117	194	231	205	384
	40	47	144	246	301	234	446
	50	59	144	246	301	234	446
	65	78	160	252	316	234	466

1、技术参数 Technical Parameter

- ◆ 公称通径: DN3-DN50
Nominal Diameter: DN3-DN50
- ◆ 适用介质: R12,R22,R502,R134a,R404a,R507,R717等制冷剂。
Applicable Medium:R12,R22,R502,R134a,R404a,R507,R717 and other refrigerants.
- ◆ 适用温度: -40°C ~ +105°C
Applicable Temperature: -40 °C ~ + 105 °C

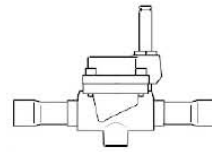

DEVSC3-25系列
DEVSC3-25 Series



2、说明 Instruction

电磁阀是一种依靠电磁力自动开关的截止阀。在工业制冷装置中，常用电磁阀作为遥控截止阀、双位调节系统的调节机关或安全保护设备。它适用于各种气体、液体制冷剂等介质。

Solenoid Valve is kind of automatic stop valve that relies on Solenoid force. In industrial refrigeration installations, Solenoid Valves are commonly used as remote-control stop valves, two-position adjustment systems, or safety protection equipment. It is suitable for various gases, liquid refrigerants and other media.

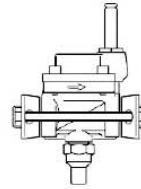

DEVS15-25系列
DEVS15-25 Series

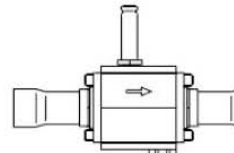

DEVSC32-40系列
DEVSC32-40 Series



3、订货 Order Goods

- ◆ 需指定型号
Please tell us the model you want when ordering.
DEVS20 It means DN20 Solenoid Valve(steel).
- ◆ 例: DEVSC20
E.g.: DEVSC20
表示DN20电磁阀 (铜)
It is means DN20 Solenoid Valve(copper).
DEVS20
DEVS20
表示DN20电磁阀 (钢)
It is means DN20 Solenoid Valve(steel).

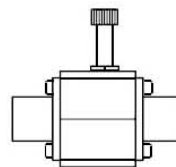

DEVS32-50系列
DEVS32-50 Series



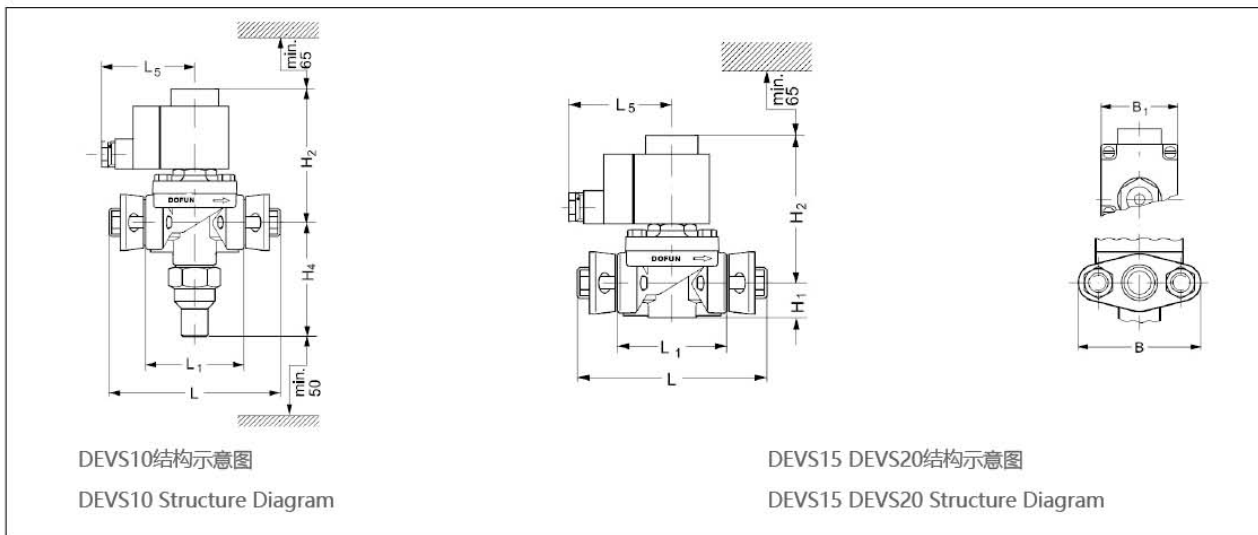

型号 Model	H ₁ mm	H ₂ mm	H ₄ mm	L mm	L ₁ mm	L ₅ mm		B mm	B ₁ (max) mm	重量 Weight (KG)
						10w	12/20w			
DEVS3		84		127	84	75	85	80	68	1.5
DEVS10	22	100	81	81	100	75	85	80	68	1.7
DEVS15		100	81	81	100	75	85	80	68	1.8
DEVS20		110	77	77	110	75	85	75	68	2.7

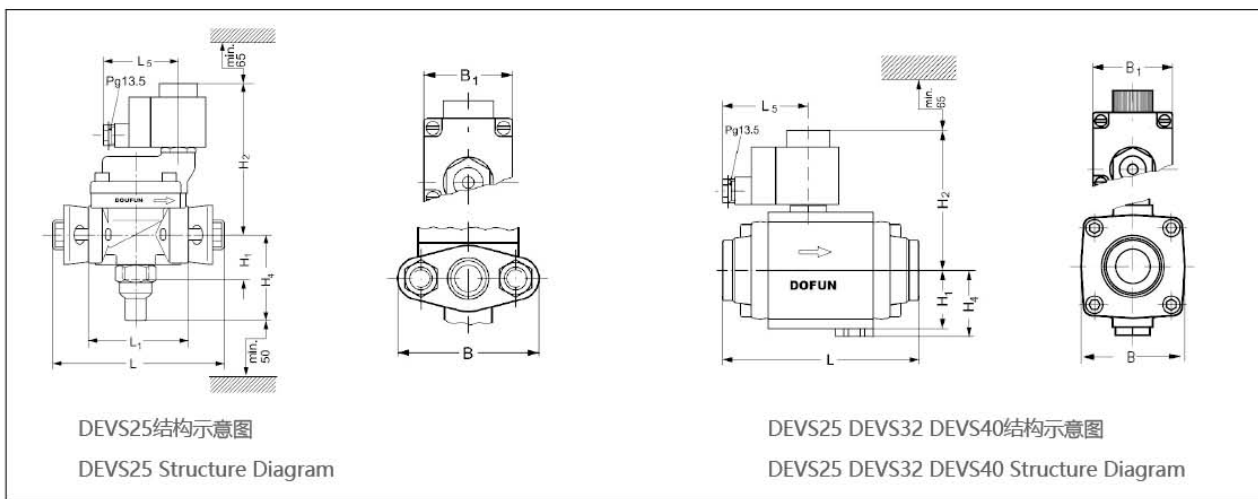

型号 Model	H ₁ mm	H ₂ mm	H ₄ mm	L mm	L ₁ mm	L ₅ mm		B mm	B ₁ (max) mm	重量 Weight (KG)
						10w	12/20w			
DEV25	46	141	78	162	92	75	75	95	68	3.0
DEVS32	47	115	53	175		75	80	80	68	4.0
DEVS40	47	115	53	175		75	80	80	68	4.0
DEVS50	47	115	53	175		75	80	80	68	4.0

1、技术参数 Technical Parameter

- ◆ 公称通径: DN40-DN125
Nominal Diameter: DN40-DN125
- ◆ 公称压力: 2.8MPa
Nominal Pressure: 2.8MPa
- ◆ 适用介质: R12,R22,R502,R134a,R404a,R507,R717等制冷剂。
Applicable Medium: R12, R22, R502, R134a, R404a, R507, R717 and other refrigerants.
- ◆ 适用温度: -46°C ~ +120°C
Applicable Temperature: -46 °C ~ + 120 °C
- ◆ 本产品具备手动开启功能, 保证系统可靠运行。
The product has a manual opening function to ensure the reliable operation of the system.
- ◆ 连接方式: 两端法兰
Connection Method: flanges at both ends.

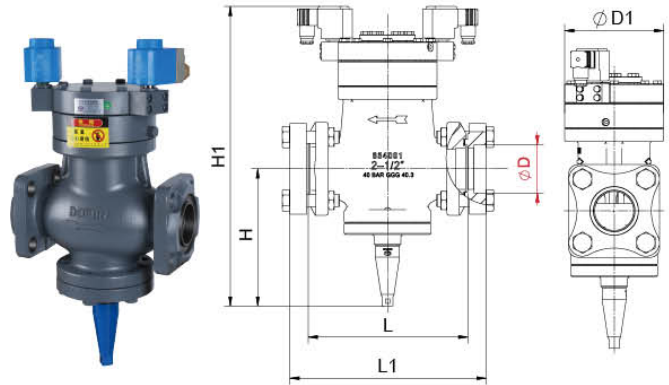

2、说明 Instruction

两步开启电磁阀开启状态有2个模块电磁导阀依次控制, 使其处于关闭、10%开启、100%开启3种状态。实际使用中可根据实际情况调整3种状态的时间间隔, 从而实现理想的运行效果, 适用于排气、需要切断、关闭的管路、热气融霜管路, 采用两步开启进行平衡, 然后全开, 避免液击。

The DGSV-2C has two module solenoid pilot valves controlled in turn to make them in three states: closed, 10% open, and 100% open. In actual use, the time interval of the three states can be adjusted according to the actual situation, so as to achieve the ideal operating effect. It is suitable for exhaust, pipelines that need to be shut off and closed, and hot gas defrosting pipelines. Open fully to avoid liquid strikes.

3、订货 Order Goods

- ◆ 需指定型号
Please tell us the model you want when ordering.
- ◆ 例: DGSV50-2C
E.g.:DGSV50-2C
表示: DN50两步开启电磁阀
It is means DN50 Two-step Open Solenoid Valve

两步开启电磁阀 Two-Step Open Solenoid Valve							
型号 Model	通径 Nominal Diameter (DN)	尺寸 (mm)Size (mm)					
		φD	φD1	L	L1	H	H1
DGSV-2C	25	34	117	194	231	210	462
	32	40	117	194	231	210	462
	40	47	144	246	301	234	515
	50	59	144	246	301	234	515
	65	78	160	252	316	234	537
	80	91	176	311	376	337	658
	100	110	222	361	433	355	715
	125	135	257	394	471	361	707

1、技术参数 Technical Parameter

- 公称通径: DN15-DN350
Nominal Diameter: DN15-DN350
- 公称压力: 4.0MPa
Nominal Pressure: 4.0MPa
- 适用介质: R12,R22,R502,R134a,R404a,R507,R717等制冷剂。
Applicable Medium: R12, R22, R502, R134a, R404a, R507, R717 and other refrigerants.
- 适用温度: $-46^{\circ}\text{C} \sim +150^{\circ}\text{C}$
Applicable Temperature: $-46^{\circ}\text{C} \sim +150^{\circ}\text{C}$
- 结构形式: 角式结构代号A 直通结构代号S
Structure Form: Angle Type Structure code is A
Straight Type Structure code is S

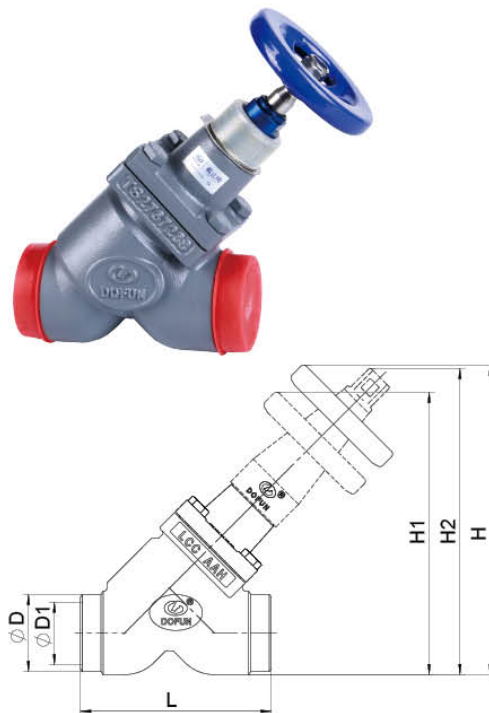
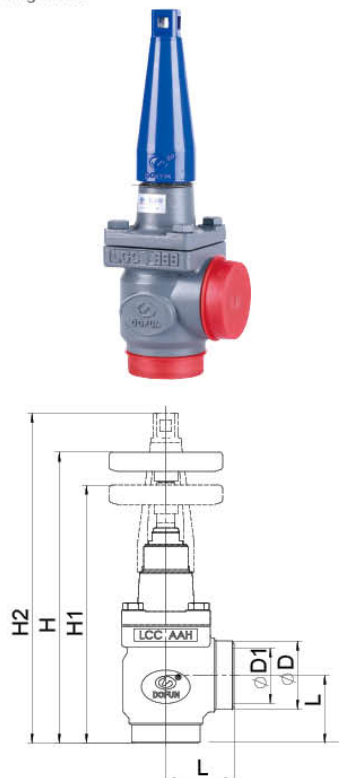

角式截止阀 Angle Type Stop Valve								
型号 Model	通径 Nominal Diameter (DN)	尺寸 (mm) Size (mm)						
		ΦD-GB	ΦD-DIN	ΦD1	L	H	H1	H2
SVD-A	15	22	21.3	15	45	203	189	230
	20	27	27	20	45	203	189	230
	25	32	33.7	25	45	203	189	230
	32	38	42.4	32	56	265	247	309
	40	45	48.3	38	56	265	247	309
	50	57	60.3	49	60	257	237	292
	65	76	76	62	90	287	263	324
	80	89	89	76	106	328	300	378
	100	108	114	96	121	368	331	414
	125	133	139.7	120	133	502	442	554
	150	159	168	150	146	546	467	591
	200	219	219	200	184	502	537	757
	250	273	273	250	210	546	603	757
	300	325	324	300	240	502	680	865
350	377	377	350	285	502	781	995	

直通截止阀 Straight Type Stop Valve								
型号 Model	通径 Nominal Diameter (DN)	尺寸 (mm) Size (mm)						
		ΦD-GB	ΦD-DIN	ΦD1	L	H	H1	H2
SVD-S	15	22	21.3	15	120	175	166	174
	20	27	27	20	120	175	166	174
	25	32	33.7	25	120	175	166	174
	32	38	42.4	32	156	219	206	236
	40	45	48.3	38	156	219	206	236
	50	57	60.3	49	149	242	228	239
	65	76	76	62	176	277	259	268
	80	89	89	76	216	323	303	312
	100	108	114	96	264	380	354	353
	125	133	139.7	120	330	520	478	464
	150	159	168	150	370	577	521	513
	200	219	219	200	460	705	636	623
	250	273	273	250	560	690	603	757
	300	325	324	300	655	925	830	810

1、技术参数 Technical Parameter

- ◆ 公称口径: DN15-DN65
Nominal Diameter: DN15-DN65
- ◆ 公称压力: 4.0MPa
Nominal Pressure: 4.0MPa
- ◆ 适用介质: R12,R22,R502,R134a,R404a,R507,R717 等制冷剂。
Applicable Medium: R12, R22, R502, R134a, R404a, R507, R717 and other refrigerants.
- ◆ 适用温度: -46°C ~ +150°C
Applicable Temperature: -46 °C ~ +150 °C
- ◆ 结构形式: 角式结构代号 A 直通结构代号 S
Structure Form: Angle Type Structure code is A
Straight Type Structure code is S
- ◆ 调节阀芯有 A、B 两种锥形阀芯, A 芯用于膨胀调节, B 芯用于流量调节
The regulating spool has two conical spools, A and B, A core is used for expansion adjustment, and B core is used for throttling adjustment.

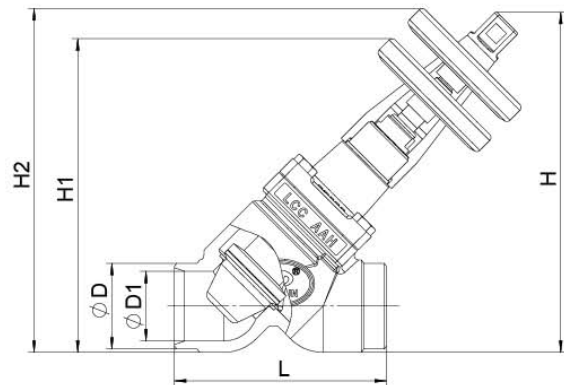
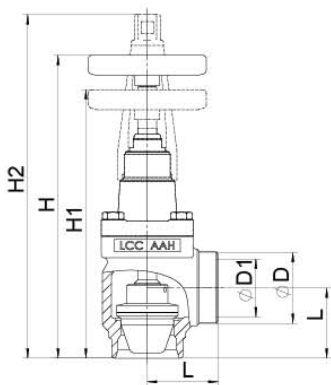

角式节流阀 Angle Type Regulating Valve								
型号 Model	通径 Nominal Diameter (DN)	尺寸 (mm) Size (mm)						
		ΦD-GB	ΦD-DIN	ΦD1	L	H	H1	H2
TVD-A	15	22	21.3	15	45	203	189	230
	20	27	27	20	45	203	189	230
	25	32	33.7	25	45	203	189	230
	32	38	42.4	32	56	265	247	309
	40	45	48.3	38	56	265	247	309
	50	57	60.3	49	60	257	237	292
	65	76	76	62	90	287	263	324

直通节流阀 Straight Type Regulating Valve								
型号 Model	通径 Nominal Diameter (DN)	尺寸 (mm) Size (mm)						
		ΦD-GB	ΦD-DIN	ΦD1	L	H	H1	H2
TVD-S	15	22	21.3	15	120	175	166	174
	20	27	27	20	120	175	166	174
	25	32	33.7	25	120	175	166	174
	32	38	42.4	32	156	219	206	236
	40	45	48.3	38	156	219	206	236
	50	57	60.3	49	149	242	228	239
	65	76	76	62	176	277	259	268

1、技术参数 Technical Parameter

- ◆ 公称通径: DN15-DN150
Nominal Diameter: DN15-DN150
- ◆ 公称压力: 4.0MPa
Nominal Pressure: 4.0MPa
- ◆ 适用介质: R12,R22,R502,R134a,R404a,R507,R717等制冷剂。
Applicable Medium: R12, R22, R502, R134a, R404a, R507, R717 and other refrigerants.
- ◆ 适用温度: -46°C ~ +150°C
Applicable Temperature: -46 °C ~ + 150 °C
- ◆ 结构形式: 角式结构代号A 直通结构代号S
Structure Form: Angle Type Structure code is A
Straight Type Structure code is S

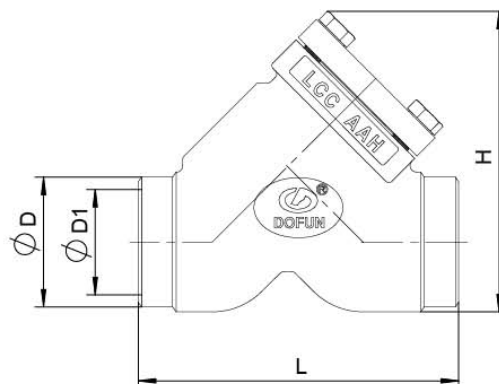
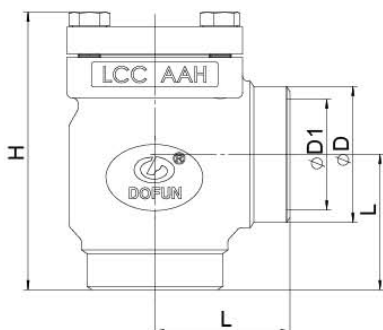

角式止回阀 Angel Type Check Valve						
型号 Model	通径 Nominal Diameter (DN)	尺寸 (mm) Size (mm)				
		ΦD-GB	ΦD-DIN	ΦD1	L	H
CVD-A	15	22	21.3	15	45	108
	20	27	27	20	45	108
	25	32	33.7	25	45	108
	32	38	42.4	32	56	136
	40	45	48.3	38	56	136
	50	57	60.3	49	60	124
	65	76	76	62	90	147
	80	89	89	76	106	185.5
	100	108	114	96	121	248
	125	133	139.7	120	133	270
	150	159	168	150	146	300

直通止回阀 Straight Type Check Valve						
型号 Model	通径 Nominal Diameter (DN)	尺寸 (mm) Size (mm)				
		ΦD-GB	ΦD-DIN	ΦD1	L	H
CVD-S	15	22	21.3	15	120	103
	20	27	27	20	120	103
	25	32	33.7	25	120	103
	32	38	42.4	32	156	131
	40	45	48.3	38	156	131
	50	57	60.3	49	149	140
	65	76	76	62	176	164
	80	89	89	76	254	215
	100	108	114	96	264	261
	125	133	139.7	120	320	316

1、技术参数 Technical Parameter

- 公称通径: DN15-DN150
Nominal Diameter: DN15-DN150
- 公称压力: 4.0MPa
Nominal Pressure: 4.0MPa
- 适用介质: R12,R22,R502,R134a,R404a,R507,R717等制冷剂。
Applicable Medium: R12,R22,R502,R134a,R404a,R507,R717 and other refrigerants.
- 适用温度: $-46^{\circ}\text{C} \sim +150^{\circ}\text{C}$
Applicable Temperature: $-46^{\circ}\text{C} \sim +150^{\circ}\text{C}$
- 结构形式: 角式结构代号A 直通结构代号S
Structure Form: Angle Type Structure code is A
Straight Type Structure code is S

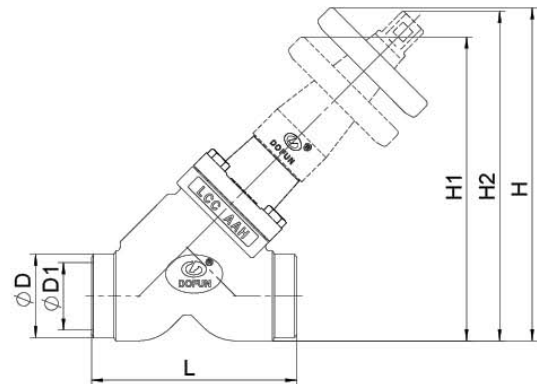
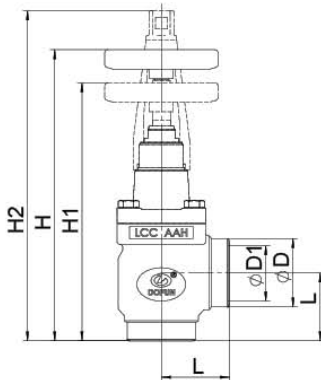

角式截止止回阀 Angle Type Regulating Valve								
型号 Model	通径 Nominal Diameter (DN)	尺寸 (mm) Size (mm)						
		ΦD-GB	ΦD-DIN	ΦD1	L	H	H1	H2
SCV-A	15	22	21.3	15	45	203	189	230
	20	27	27	20	45	203	189	230
	25	32	33.7	25	45	203	189	230
	32	38	42.4	32	56	265	247	309
	40	45	48.3	38	56	265	247	309
	50	57	60.3	49	60	257	237	292
	65	76	76	62	90	287	263	324
	80	89	89	76	106	328	300	378
	100	108	114	96	121	368	331	414
	125	133	139.7	120	133	502	442	554
	150	159	168	150	146	546	471	591

直通截止止回阀 Straight Type Stop Check Valve								
型号 Model	通径 Nominal Diameter (DN)	尺寸 (mm) Size (mm)						
		ΦD-GB	ΦD-DIN	ΦD1	L	H	H1	H2
SCV-S	15	22	21.3	15	120	175	166	174
	20	27	27	20	120	175	166	174
	25	32	33.7	25	120	175	166	174
	32	38	42.4	32	156	219	206	236
	40	45	48.3	38	156	219	206	236
	50	57	60.3	49	149	242	228	239
	65	76	76	62	176	277	259	268
	80	89	89	76	216	323	303	312
	100	108	114	96	264	380	354	353
	125	133	139.7	120	330	520	478	464

1、技术参数 Technical Parameter

- ◆ 公称通径: DN15-DN150
Nominal Diameter: DN15-DN150
- ◆ 公称压力: 4.0MPa
Nominal Pressure: 4.0MPa
- ◆ 适用介质: R12,R22,R502,R134a,R404a,R507,R717等制冷剂。
Applicable Medium: R12, R22, R502, R134a, R404a, R507, R717 and other refrigerants.

- ◆ 适用温度: -46°C~+150°C
Applicable Temperature: -46 °C ~ + 150 °C
- ◆ 滤网规格有150目、100目、72目、38目, 可以根据不同的管路系统要求选配。
The specifications of the filter screen are 150 mesh, 100 mesh, 72 mesh, 38 mesh, which can be selected according to the requirements of different pipeline.

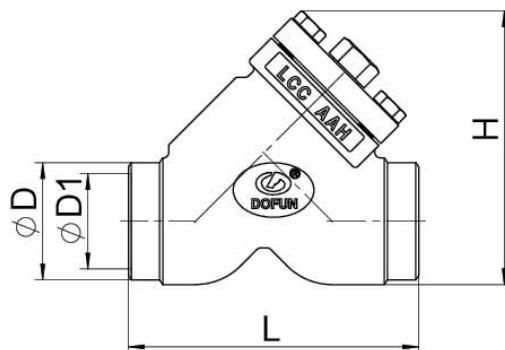
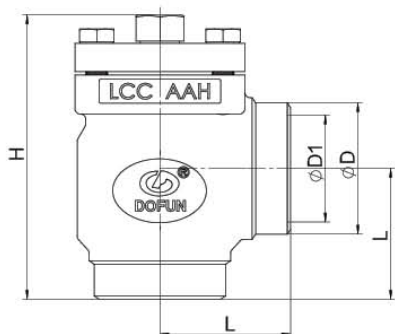

角式过滤器 Angle Type Filter						
型号 Model	通径 Nominal Diameter (DN)	尺寸 (mm) Size (mm)				
		ΦD-GB	ΦD-DIN	ΦD1	L	H
CVD-A	15	22	21.3	15	45	115.5
	20	27	27	20	45	115.5
	25	32	33.7	25	45	115.5
	32	38	42.4	32	56	141.5
	40	45	48.3	38	56	141.5
	50	57	60.3	49	60	130
	65	76	76	62	90	148
	80	89	89	76	106	224
	100	108	108	96	121	253
	125	133	133	120	133	273.5
	150	159	168	144	146	311
	200	219	219	200	184	382

直通过滤器 Straight Type Filter						
型号 Model	通径 Nominal Diameter (DN)	尺寸 (mm) Size (mm)				
		ΦD-GB	ΦD-DIN	ΦD1	L	H
CVD-S	15	22	21.3	15	120	103
	20	27	27	20	120	103
	25	32	33.7	25	120	103
	32	38	42.4	32	156	131
	40	45	48.3	38	156	131
	50	57	60.3	49	149	140
	65	76	76	62	176	164
	80	89	89	76	254	215
	100	108	108	96	264	261
	125	133	133	120	320	316
	150	159	168	144	370	371
	200	219	219	200	184	482

1、技术参数 Technical Parameter

- 公称通径: DN15-DN150
Nominal Diameter: DN15-DN150
- 公称压力: 6.3MPa
Nominal Pressure: 6.3MPa
- 适用介质: R12,R22,R502,R134a,R404a,R507,R717,R744等制冷剂。
Applicable Medium: R12, R22, R502, R134a, R404a, R507, R717, R744 and other refrigerants.

- 适用温度: -46°C ~ +150°C
Applicable Temperature: -46 °C ~ + 150 °C
- 结构形式: 角式结构代号A 直通结构代号S
Structure Form: Angle Type Structure code is A
Straight Type Structure code is S

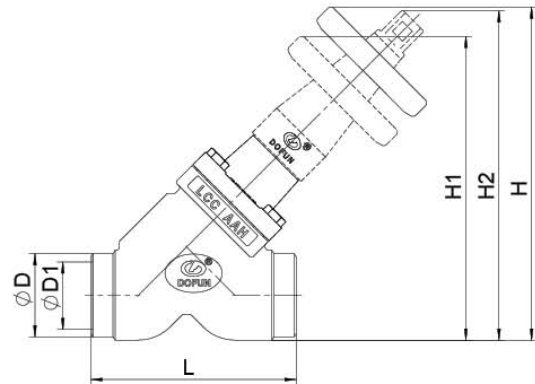
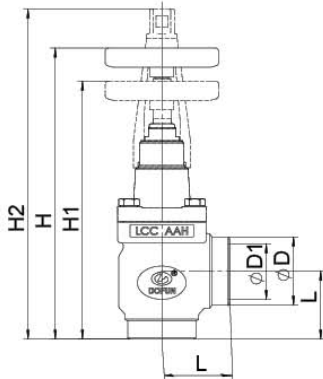

角式PN63截止阀 Angle Type PN63 Stop Valve								
型号 Model	通径 Nominal Diameter (DN)	尺寸 (mm) Size (mm)						
		ΦD-GB	ΦD-DIN	ΦD1	L	H	H1	H2
SVD-HA	15	22	21.3	15	45	203	189	230
	20	27	27	20	45	203	189	230
	25	32	33.7	25	45	203	189	230
	32	38	42.4	32	56	265	247	309
	40	45	48.3	38	56	265	247	309
	50	57	60.3	49	60	257	237	292
	65	76	76	62	90	287	263	324
	80	89	89	76	106	328	300	378
	100	108	114	96	121	368	331	414
	125	133	139.7	120	133	502	442	554
150	159	168	150	146	546	467	591	

直通PN63截止阀 Straight Type PN63 Stop Valve								
型号 Model	通径 Nominal Diameter (DN)	尺寸 (mm) Size (mm)						
		ΦD-GB	ΦD-DIN	ΦD1	L	H	H1	H2
SVD-HS	15	22	21.3	15	120	175	166	174
	20	27	27	20	120	175	166	174
	25	32	33.7	25	120	175	166	174
	32	38	42.4	32	156	219	206	236
	40	45	48.3	38	156	219	206	236
	50	57	60.3	49	149	242	228	239
	65	76	76	62	176	277	259	268
	80	89	89	76	216	323	303	312
	100	108	114	96	264	380	354	353
	125	133	139.7	120	330	520	478	464
	150	159	168	150	370	570	525	513

1、技术参数 Technical Parameter

- ◆ 公称通径: DN15-DN65
Nominal Diameter: DN15-DN65
- ◆ 公称压力: 6.3MPa
Nominal Pressure: 6.3MPa
- ◆ 适用介质: R12,R22,R502,R134a,R404a,R507,R717,R744 等制冷剂。
Applicable Medium: R12, R22, R502, R134a, R404a, R507, R717, R744 and other refrigerants.
- ◆ 适用温度: -46°C ~ +150°C
Applicable Temperature: -46 °C ~ +150 °C
- ◆ 结构形式: 角式结构代号 A 直通结构代号 S
Structure Form: Angle Type Structure Code is A
Straight Type Structure Code is S
- ◆ 调节阀芯有 A、B 两种锥形阀芯, A 芯用于膨胀调节, B 芯用于流量调节
The regulating spool has two conical spools, A and B, A core is used for expansion adjustment, and B core is used for throttling adjustment.

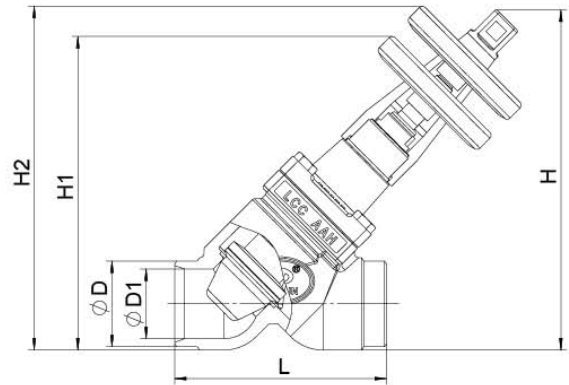
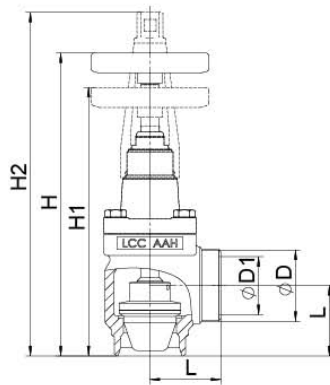

角式PN63节流阀 Angle Type PN63 Regulating Valve								
型号 Model	通径 Nominal Diameter (DN)	尺寸 (mm) Size (mm)						
		ΦD-GB	ΦD-DIN	ΦD1	L	H	H1	H2
TVD-HA	15	22	21.3	15	45	203	189	230
	20	27	27	20	45	203	189	230
	25	32	33.7	25	45	203	189	230
	32	38	42.4	32	56	265	247	309
	40	45	48.3	38	56	265	247	309
	50	57	60.3	49	60	257	237	292
	65	76	76	62	90	287	263	324

直通PN63节流阀 Straight Type PN63 Regulating Valve								
型号 Model	通径 Nominal Diameter (DN)	尺寸 (mm) Size (mm)						
		ΦD-GB	ΦD-DIN	ΦD1	L	H	H1	H2
TVD-HS	15	22	21.3	15	120	175	166	174
	20	27	27	20	120	175	166	174
	25	32	33.7	25	120	175	166	174
	32	38	42.4	32	156	219	206	236
	40	45	48.3	38	156	219	206	236
	50	57	60.3	49	149	242	228	239
	65	76	76	62	176	277	259	268

1、技术参数 Technical Parameter

- 公称通径: DN15-DN150
Nominal Diameter: DN15-DN150
- 公称压力: 6.3MPa
Nominal Pressure: 6.3MPa
- 适用介质: R12,R22,R502,R134a,R404a,R507,R717,R744等制冷剂。
Applicable Medium: R12, R22, R502, R134a, R404a, R507, R717, R744 and other refrigerants.

- 适用温度: -46°C ~ +150°C
Applicable Temperature: -46 °C ~ + 150 °C
- 结构形式: 角式结构代号A 直通结构代号S
Structure Form: Angle Type Structure Code is A
Straight Type Structure Code is S

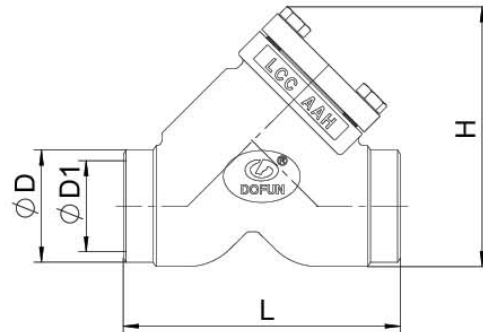
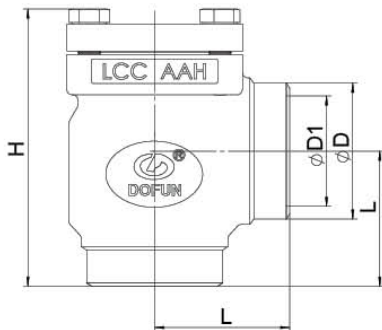

角式 PN63 止回阀 Angel Type PN63 Check Valve						
型号 Model	通径 Nominal Diameter (DN)	尺寸 (mm) Size (mm)				
		ΦD-GB	ΦD-DIN	ΦD1	L	H
CVD-HA	15	22	21.3	15	45	108
	20	27	27	20	45	108
	25	32	33.7	25	45	108
	32	38	42.4	32	56	136
	40	45	48.3	38	56	136
	50	57	60.3	49	60	124
	65	76	76	62	90	147
	80	89	89	76	106	185.5
	100	108	114	96	121	248
	125	133	139.7	120	133	270
150	159	168	150	146	300	

直通 PN63 止回阀 Straight Type PN63 Check Valve						
型号 Model	通径 Nominal Diameter (DN)	尺寸 (mm) Size (mm)				
		ΦD-GB	ΦD-DIN	ΦD1	L	H
CVD-HS	15	22	21.3	15	120	103
	20	27	27	20	120	103
	25	32	33.7	25	120	103
	32	38	42.4	32	156	131
	40	45	48.3	38	156	131
	50	57	60.3	49	149	140
	65	76	76	62	176	164
	80	89	89	76	254	215
	100	108	114	96	264	261
	125	133	139.7	120	320	316

1、技术参数 Technical Parameter

- 公称通径: DN15-DN150
Nominal Diameter: DN15-DN150
- 公称压力: 6.3MPa
Nominal Pressure: 6.3MPa
- 适用介质: R12,R22,R502,R134a,R404a,R507,R717,R744等制冷剂。
Applicable Medium: R12, R22, R502, R134a, R404a, R507, R717, R744 and other refrigerants.

- 适用温度: -46°C~+150°C
Applicable Temperature: -46 °C ~ + 150 °C
- 结构形式: 角式结构代号A 直通结构代号S
Structure Form: Angle Type Structure Code is A
Straight Type Structure Code is S

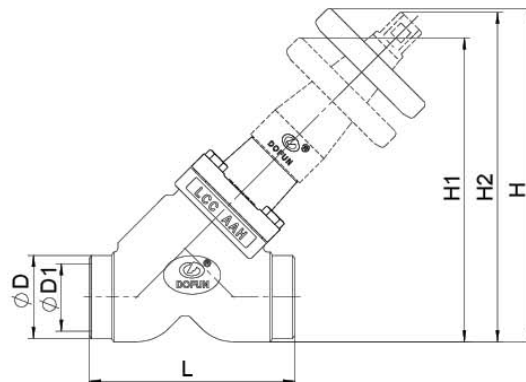
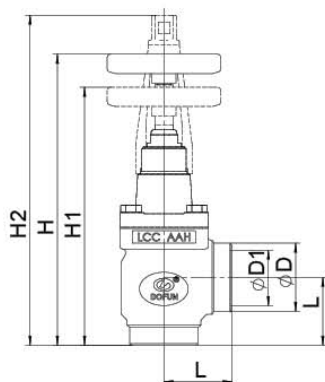

角式PN63截止止回阀 Angle Type PN63 Stop Check Valve								
型号 Model	通径 Nominal Diameter (DN)	尺寸 (mm) Size (mm)						
		ΦD-GB	ΦD-DIN	ΦD1	L	H	H1	H2
SCV-HA	15	22	21.3	15	45	203	189	230
	20	27	27	20	45	203	189	230
	25	32	33.7	25	45	203	189	230
	32	38	42.4	32	56	265	247	309
	40	45	48.3	38	56	265	247	309
	50	57	60.3	49	60	257	237	292
	65	76	76	62	90	287	263	324
	80	89	89	76	106	328	300	378
	100	108	114	96	121	368	331	414
	125	133	139.7	120	133	502	442	554
150	159	168	150	146	546	472	591	

直通PN63截止止回阀 Straight Type PN63 Stop Check Valve								
型号 Model	通径 Nominal Diameter (DN)	尺寸 (mm) Size (mm)						
		ΦD-GB	ΦD-DIN	ΦD1	L	H	H1	H2
SVD-HS	15	22	21.3	15	120	175	166	174
	20	27	27	20	120	175	166	174
	25	32	33.7	25	120	175	166	174
	32	38	42.4	32	156	219	206	236
	40	45	48.3	38	156	219	206	236
	50	57	60.3	49	149	242	228	239
	65	76	76	62	176	277	259	268
	80	89	89	76	216	323	303	312
	100	108	114	96	264	380	354	353
	125	133	139.7	120	330	520	478	464

1、技术参数 Technical Parameter

- 公称通径: DN15-DN150
Nominal Diameter: DN15-DN150
- 公称压力: 6.3MPa
Nominal Pressure: 6.3MPa
- 适用介质: R12,R22,R502,R134a,R404a,R507,R717,R744等制冷剂。
Applicable Medium: R12, R22, R502, R134a, R404a, R507, R717, R744 and other refrigerants.

- 适用温度: -46°C ~ +150°C
Applicable Temperature: -46 °C ~ + 150 °C
- 滤网规格有150目、100目、72目、38目, 可以根据不同的管路系统要求选配。
The specifications of the filter screen are 150 mesh, 100 mesh, 72 mesh, 38 mesh, which can be selected according to the requirements of different pipeline.

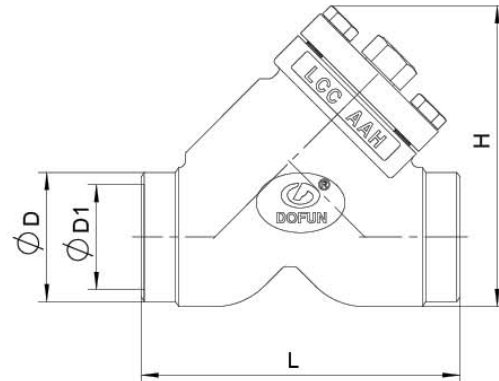
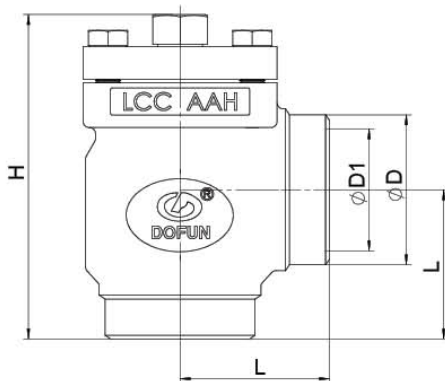

角式过滤器 Angel Type Filter						
型号 Model	通径 Nominal Diameter (DN)	尺寸 (mm) Size (mm)				
		ΦD-GB	ΦD-DIN	ΦD1	L	H
FVD-HA	15	22	21.3	15	45	115.5
	20	27	27	20	45	115.5
	25	32	33.7	25	45	115.5
	32	38	42.4	32	56	141.5
	40	45	48.3	38	56	141.5
	50	57	60.3	49	60	130
	65	76	76	62	90	148
	80	89	89	76	106	224
	100	108	114	96	121	253
	125	133	139.7	120	133	273.5
150	159	168	144	146	311	

直通过过滤器 Straight Type Filter						
型号 Model	通径 Nominal Diameter (DN)	尺寸 (mm) Size (mm)				
		ΦD-GB	ΦD-DIN	ΦD1	L	H
FVD-HS	15	22	21.3	15	120	103
	20	27	27	20	120	103
	25	32	33.7	25	120	103
	32	38	42.4	32	156	131
	40	45	48.3	38	156	131
	50	57	60.3	49	149	140
	65	76	76	62	176	164
	80	89	89	76	254	215
	100	108	114	96	264	261
	125	133	139.7	120	320	316
150	159	168	144	370	371	

1、技术参数 Technical Parameter

- ◆ 公称口径: DN15-DN100
Nominal Diameter: DN15-DN100
- ◆ 公称压力: 6.3MPa
Nominal Pressure: 6.3MPa
- ◆ 适用介质: 适用介质: R12,R22,R502,R134a,R404a,R507,R717,R744 等制冷剂。
Applicable Medium: R12, R22, R502, R134a, R404a, R507, R717, R744 and other refrigerants.
- ◆ 适用温度: -60°C ~ +150°C
Applicable Temperature: -60 °C ~ + 150 °C
- ◆ 结构形式: 角式结构代号 A 直通结构代号 S
Structure Form: Angle Type structure code is A
Straight Type structure code is S

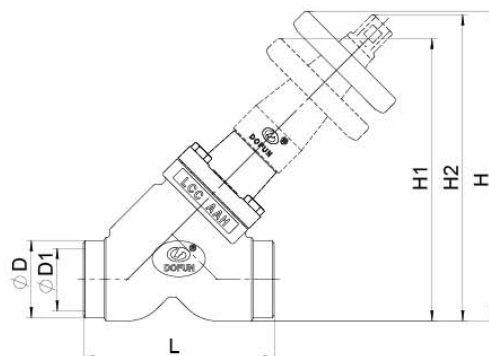
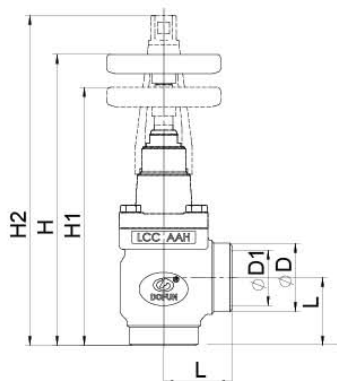

角式不锈钢截止阀 Stainless Steel Angel Type Stop Valve								
型号 Model	通径 Nominal Diameter (DN)	尺寸 (mm) Size (mm)						
		ΦD-GB	ΦD-DIN	ΦD1	L	H	H1	H2
SSVD-A	15	22	21.3	15	45	203	189	230
	20	27	27	20	45	203	189	230
	25	32	33.7	25	45	203	189	230
	32	38	42.4	32	56	265	247	309
	40	45	48.3	38	56	265	247	309
	50	57	60.3	49	60	257	237	292
	65	76	76	62	90	287	263	324
	80	89	89	76	106	328	300	378
	100	108	114	96	121	368	331	414

直通不锈钢截止阀 Stainless Steel Straight Type Stop Valve								
型号 Model	通径 Nominal Diameter (DN)	尺寸 (mm) Size (mm)						
		ΦD-GB	ΦD-DIN	ΦD1	L	H	H1	H2
SSVD-S	15	22	21.3	15	120	175	166	174
	20	27	27	20	120	175	166	174
	25	32	33.7	25	120	175	166	174
	32	38	42.4	32	156	219	206	236
	40	45	48.3	38	156	219	206	236
	50	57	60.3	49	149	242	228	239
	65	76	76	62	176	277	259	268
	80	89	89	76	216	323	303	312
	100	108	114	96	264	380	354	353

1、技术参数 Technical Parameter

- ◆ 公称通径 :DN15-DN40
Nominal diameter: DN15-DN40
- ◆ 适用温度: -46°C ~ +150°C
Applicable Temperature: -46°C ~ +150°C
- ◆ 公称压力 : 6.3MPa
Nominal Pressure: 6.3MPa
- ◆ 适用介质: R12, R22, R502, R134a, R404a, R507, R717, R744 等制冷剂。
Applicable Medium: R12, R22, R502, R134a, R404a, R507, R717, R744 and other refrigerants.
- ◆ 连接方式: 对接焊、承插焊
Connection Method: Butt Welding and Socket Welding

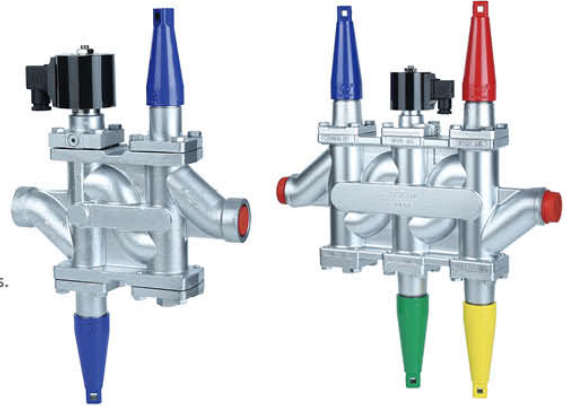

2、说明 Instruction

组合阀可用于供液、热气、液体喷射等管路中，DFCV 拥有 4 或 6 个功能模块，各种模块组合形成所需的功能，模块化的集中安装大大减少了管路中焊接点的数量，降低了泄漏的风险，建议安装在密闭的管路系统中，侧接口可以接压力表、视镜、传感器。

The DFCV can be used in pipelines such as liquid supply, hot gas, liquid injection, etc. DFCV has 4 or 6 functional modules, and various modules are combined to form the required functions. The modularized centralized installation greatly reduces the number of welding points in the pipeline, to reduce the risk of leakage, it is recommended to be installed in a closed pipeline system, and the side port can be connected to a pressure gauge, a sight glass, and a sensor.

3、模块配置 Module Configuration

代号 Model	型号 Model	代号 Model	型号 Model
DFCS	截止阀模块 stop valve	DFCF	过滤器模块 Filter
DFCE	电磁阀模块 Solenoid valve	DFCO	手动开启模块 open manually
DFCT	节流阀模块 Regulating valve	DFCSC	截止止回阀模块 Stop Check valve
DFCM	电动阀模块 Motor valve	DFCB	盲板模块 Blind module

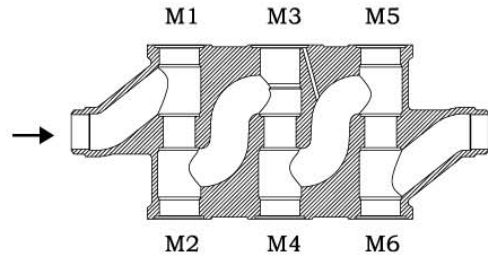

一般配置 (不包括接口类型和尺寸) General configuration (excluding interface type and size)							代码 code
应用 Application	M1	M2	M3	M4	M5	M6	
供液管路 Liquid supply line	*截止 Stop valve	*过滤 Filter	电磁 Solenoid valve	手动开启 open manually	节流 Regulating valve	截止止回 Stop Check Valve	12
供液 (无热气除霜) Liquid supply (no hot gas defrosting)	*截止 Stop valve	*过滤 Filter	电磁 Solenoid valve	手动开启 open manually	节流 Regulating valve	截止 Stop Valve	11
热气管路 hot gas line	*截止 Stop valve	*过滤 Filter	电磁 Solenoid valve	手动开启 open manually	盲板 blind plate	截止 Stop Valve	21
液体喷射 liquid jet	*截止 Stop valve	*过滤 Filter	电磁 Solenoid valve	手动开启 open manually	电动 Motor Valve	截止 Stop Valve	31
供液 (无热气除霜) Liquid supply (no hot gas defrosting)	*截止 Stop valve	*过滤 Filter	电磁 Solenoid valve	节流 Regulating Valve	/	/	14
热气管路 hot gas line	*截止 Stop valve	*过滤 Filter	电磁 Solenoid valve	手动开启 open manually	/	/	22
热气除霜 hot air defrost	*截止 Stop valve	*过滤 Filter	电磁 Solenoid valve	截止 Stop valve	/	/	33
其余配置联系公司 Contact the company for the other configuration							

4、订货 Order Goods

- ◆ 需指定型号、模块功能及数量
Need to specify the model, module function and quantity
- ◆ 如：DFCV15-4-02 表示：DN15 组合阀，4 个模块，截止 - 过滤 - 电磁 - 节流，用于供液（无热气除霜）
Indicates: DN15 combination valve, 4 modules, stop valve-filter-solenoid valve-regulating valve, for liquid supply (no hot gas defrosting)

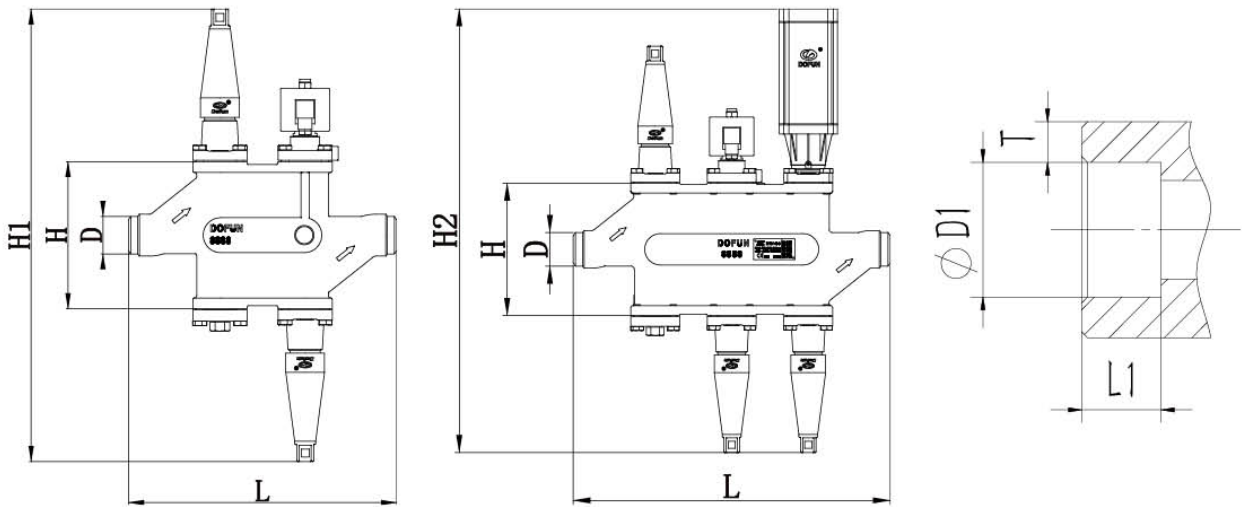

组合阀 Combination Valve									
型号 Model	通径 Nominal Diameter (DN)	尺寸 (mm) Size (mm)							
		ΦD	ΦD1	L	H	H1	H2	L1	T
DN15-4/6	15	21.3	21.9	256/346	140/190	427	529	10	6.5
DN20-4/6	20	27	27.2					13	6.5
DN25-4/6	25	33.7	33.9	346/456		584	636	13	5.6
DN32-4/6	32	42.4	42.7		6.1				
DN40-4/6	40	48.3	48.8					6.6	

H2 配置最大外形尺寸
H2 Configuration Maximum Dimension

1、技术参数 Technical Parameter

- 公称进口口径: DN25-DN50
Nominal Diameter: DN25-DN50
- 公称压力: 2.8MPa
Nominal Pressure: 2.8MPa
- 适用介质: R12, R22, R502, R134a, R404a, R507, R717等制冷剂。
Applicable Medium: R12, R22, R502, R134a, R404a, R507, R717 and other refrigerants.
- 适用温度: -46°C ~ +150°C
Applicable Temperature: -46 °C ~ + 150 °C

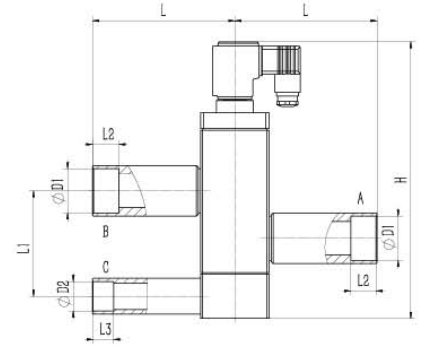

2、说明 Instruction

DSV3化霜三通阀通过电磁阀控制在制冷、除霜两路之间的转换, A接口连接蒸发器, B接口压缩机吸气, C 接口连接排气管。当电磁阀线圈失电关闭时, 通向C口处管路关闭, A、B通道打开, 介质从蒸发器流向压缩机, 压缩机正常吸气;

The DSV3 is used to control the conversion between refrigeration and defrosting through a solenoid valve. The A interface is connected to the evaporator, the B interface is connected to the compressor, and the C interface is connected to the exhaust pipe. When the solenoid valve coil is de-energized and closed, the pipeline leading to port C is closed, channels A and B are opened, the medium flows from the evaporator to the compressor, and the compressor normally sucks in;

当电磁阀线圈得电打开时, 通向B接口处管路关闭, 此时排气管中的热气通过C口, 从A口进入蒸发器, 进行化霜。

When the solenoid valve coil is energized and opened, the pipeline leading to the B interface is closed. At this time, the hot air in the exhaust pipe passes through the C port and enters the evaporator from the A port for defrosting.

安装时, 电磁阀线圈不得朝下, 保持阀内部清洁。DSV3化霜三通阀只能与排气集成总管连接, 不允许与排气主管直接相连。

When installing, the solenoid valve coil must not face downwards to keep the inside of the valve clean. The DSV3 Defrosting Three-way Valve can only be connected to the exhaust integrated main pipe, and not directly connected to the exhaust main pipe.

3、订货 Order Goods

- 需指定型号、公称进口口径
Please tell us the model, nominal diameter
- 如: DSV3-25
E.g.: DSV3-25
表示进口口径DN25化霜三通阀
It is means inlet nominal diameter DN25 Defrosting Three-way valve

化霜三通阀 Defrosting Three-way Valve							
型号 Model	尺寸 (mm) Size (mm)						
	D1	D2	L	L1	L2	L3	H
DSV3-25	34	28	135	100	25	20	263
DSV3-32	42	28	135	100	25	20	263
DSV3-40	49	35	138	130	20	20	317
DSV3-50	58.5	35	138	130	20	20	317

1、技术参数 Technical Parameter

- ◆ 公称口径：DN25-DN80
Nominal Diameter: DN25-DN80
- ◆ 公称压力：4.0MPa
Nominal Pressure: 4.0MPa
- ◆ 适用介质：氟、氨等制冷剂
Applicable Medium: Freon, Ammonia and other refrigerants.
- ◆ 适用油：各种通用型冷冻油
Applicable Oil: Various general-purpose refrigeration oils
- ◆ 适用温度：-46°C ~ +150°C
Applicable Temperature: -46°C ~ +150°C
- ◆ 量程温度：49°C (A)、54°C (B)、60°C (C)、77°C (D)、35°C (E)
Range Temperature: 49°C (A)、54°C (B)、60°C (C)、77°C (D)、35°C (E)
- ◆ 最小操作温度：≥ -10°C
Minimum Operating Temperature: ≥ -10°C



2、说明 Instructions

OTRV 油温调节阀是一个制冷的三通阀，通过对螺杆压缩机或离心压缩机润滑油系统中热油和冷油进行混合用于维持压缩机的油温处于稳定的水平，也可以作为方向换向阀使用。

阀体接口分 A\B\C 标识，作为油温调节阀使用时，A 接压缩机，B 接高温油，C 接冷油，当温度达到感应元件的温度时，自动控制 B 和 C 的流量，从而达到调节油温的目的。作为方向换向阀使用时，A 为入口，B 接压缩机管路，C 接冷油。

The OTRV is a three-way valve for refrigeration. It is used to maintain the oil temperature of the compressor at a stable level by mixing the hot oil and cold oil in the lubricating oil system of the screw compressor or centrifugal compressor. It can also be used as a directional control valve.

The valve body interface is marked with A\B\C. When used as an oil temperature regulating valve, A is connected to the compressor, B is connected to the high-temperature oil, and C is connected to the cold oil. When the temperature reaches the temperature of the sensing element, the flow of B and C is automatically controlled. So as to achieve the purpose of adjusting the oil temperature. When used as a directional reversing valve, A is the inlet, B is connected to the compressor pipeline, and C is connected to the cooling oil.

3、订货 Order Goods

- ◆ 默认感应元件（温包）温度量程：49°C (A)，默认加工 DIN 接口
Default sensing element (temperature bulb) temperature range: Default processing DIN interface
- ◆ 指定型号和量程温度：表示 DN50 油温调节阀，感应温包温度 49°
Specified model and range temperature: OTRV50A Indicates DN50 oil temperature regulating valve, the temperature of the induction temperature bulb is 49°.

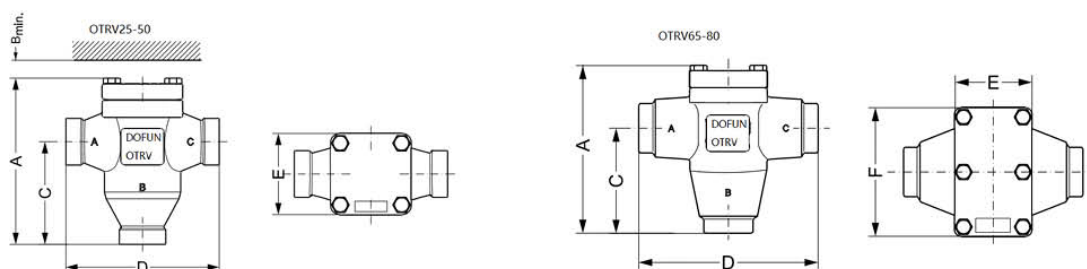

油温调节阀 Oil Temperature Regulating Valve									
型号 Model	口径 Nominal Diameter (DN)	尺寸 (mm) Size (mm)							
		接口尺寸 connection Size		H1	H	L	A	B	C
		GB	DIN						
OTRV	25	32	33.7	178	110	165	91	80	-
	32	38	42.4	178	110	165	91	80	-
	40	45	48.3	215	138	195	110	90	-
	50	57	60.3	215	138	195	110	90	-
	65	76	76	252	138	265	115	90	190
	80	89	89	252	138	265	115	90	190

1、技术参数 Technical Parameter

- ◆ 公称通径 :DN15
Nominal Diameter: DN15
- ◆ 公称压力 :4.0MPa
Nominal Pressure: 4.0MPa
- ◆ 内置卸荷压力 :16bar
Built-in Unloading Pressure: 16bar
- ◆ 适用介质 :氨制冷剂
Applicable Medium: Ammonia refrigerant.
- ◆ 适用温度 : $-46^{\circ}\text{C} \sim +150^{\circ}\text{C}$
Applicable Temperature: $-46^{\circ}\text{C} \sim +150^{\circ}\text{C}$

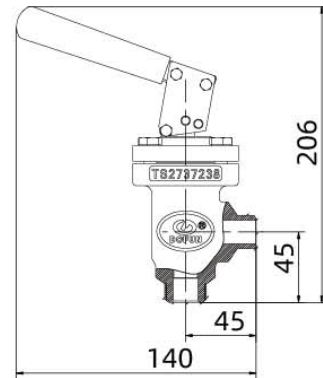

2、说明 Instruction

QCV 快速放油阀是一种氨制冷系统排油用阀门按下手柄，打开阀门
松开手柄后阀门立刻关闭。

The QCV is used for oil discharge in ammonia refrigeration system. Press the handle to open the valve. The valve closes immediately after the handle is released.

QCV 快速放油阀需要在阀前配套截止阀一起安装到系统中，为防止和截止阀直接产生积液，QCV 阀内置泄压装置，开启压力 16bar

The QCV quick drain valve needs to be installed in the system together with the shut-off valve in front of the valve.

In order to prevent liquid effusion directly with the stop valve, the QCV valve has a built-in pressure relief device with a cracking pressure of 16bar.

3、订货 Order Goods

- ◆ 默认 DN15-G3/4 接口
Default DN15-G3/4 interface
- ◆ 指定阀体连接尺寸
Specify valve body connection Size
- ◆ 阀体的不同的连接结构
Different connection structures of the valve body

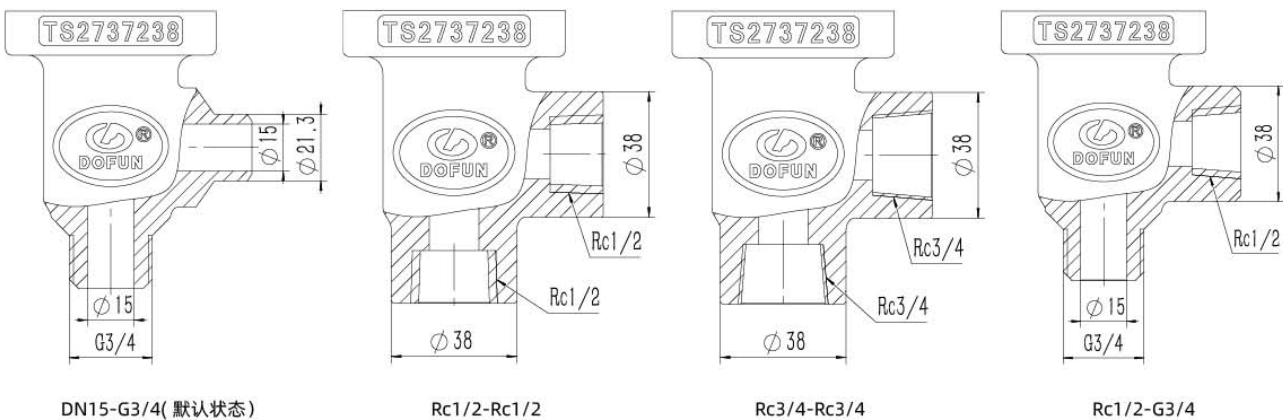

1、技术参数 Technical Parameter

- 公称通径: DN15-DN125
Nominal Diameter: DN15-DN125
- 公称压力: 4.0MPa
Nominal Pressure: 4.0MPa
- 模拟信号0-10V、4-20mA, PLC总线控制模式;
Analog Signal 0-10V, 4-20mA, PLC bus control mode;
- 模块化设计, 方便安装、保养、维修;
Modular design, easy to install, maintain and repair;
- 5级外密封结构, 保证零泄漏;
Grade 5 outer seal structure ensures zero leakage;
- 温度范围: -46°C ~ +150°C
Temperature Range: -46 °C ~ + 150 °C
- 电源电压: 24V
Power Supply Voltage: 24V
- 结构形式: 角式结构代号A 直通结构代号S
Structure Form: Angle Type Structure' s code is A
Straight Type Structure' s code is B

2、说明 Instruction

用于工业制冷各管路中的控制阀, 方便实现自动化控制
Instruction:Used for Control Valves in industrial refrigeration pipelines
easy to realize automatic control.

3、订货 Order Goods

- 需指定型号、结构形式
Please tell us the model and structure type you want when ordering.
- 例: DFMV40-A
E.g.:DFMV40-A
表示DN40角式电动阀
It is means Angle type Motor Valve.

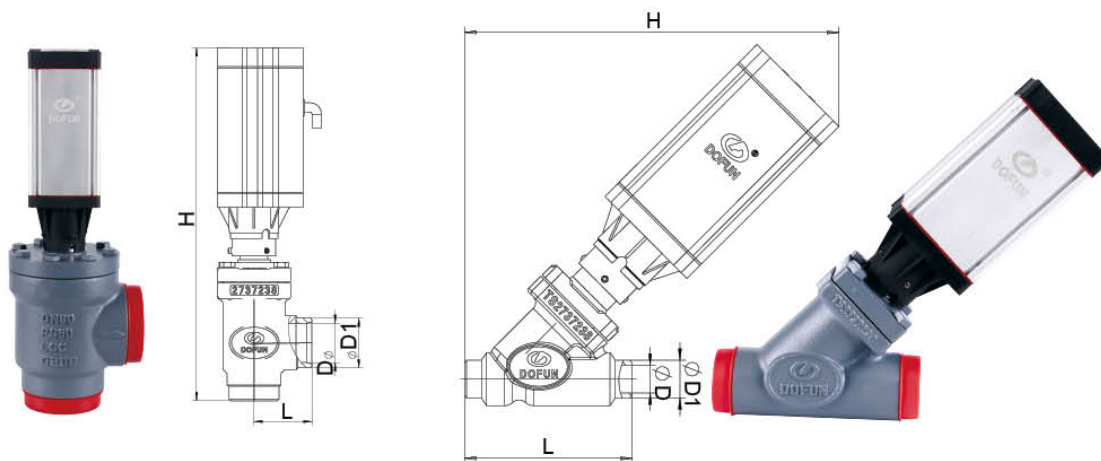

角式电动阀 Angle Type Motor Valve						
型号 Model	通径 Nominal Diameter (DN)	尺寸 (mm) Size (mm)				
		ΦD1-GB	ΦD1-DIN	ΦD1	L	H
DFMV-A	15	22	21.3	15	120	268
	20	27	27	20	45	315
	25	32	33.7	25	45	315
	32	38	42.4	32	56	368
	40	45	48.3	38	56	368
	50	57	60.3	49	60	390
	65	76	76	62	90	390
	80	89	89	76	106	430
	100	108	114	96	121	468
	125	133	139.7	120	133	495

直通电动阀 Straight Type Motor Valve						
型号 Model	通径 Nominal Diameter (DN)	尺寸 (mm) Size (mm)				
		ΦD1-GB	ΦD1-DIN	ΦD1	L	H
DFMV-S	15	22	21.3	15	120	268
	20	27	27	20	120	268
	25	32	33.7	25	120	268
	32	38	42.4	32	156	335
	40	45	48.3	38	156	335
	50	57	60.3	49	149	352
	65	76	76	62	176	352
	80	89	89	76	216	395
	100	108	114	96	264	423
	125	133	139.7	120	320	443

1、技术参数 Technical Parameter

- 公称通径: DN20-DN40
Nominal Diameter: DN20-DN40
- 压力调整范围: 2-6.5bar, 3.5-8bar
Pressure Adjustment Range: 2-6.5bar 3.5-8bar
- 适用介质: R12,R22,R502,R134a,R404a,R507,R717,R744等制冷剂。
Applicable Medium: R12,R22,R502,R134a,R404a,R507,R717,R744 and other refrigerants.
- 适用温度: -46°C ~ +150°C
Applicable Temperature: -46 °C ~ + 150 °C

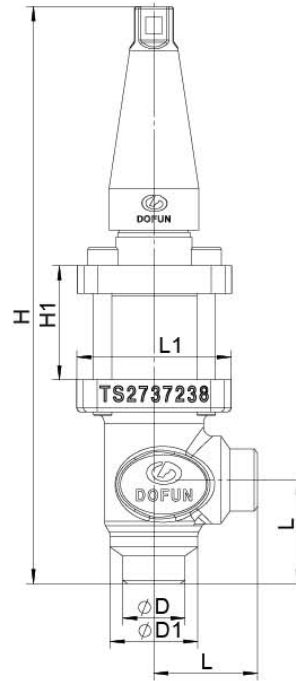

溢流阀 Overflow Valve							
型号 Model	通径 Nominal Diameter (DN)	尺寸 (mm) Size (mm)					
		φD	φD1	L	L1	H	H1
OFD	20	26.9	38	45	60	250.5	49.5
	25	33.7	38	45	60	250.5	49.5
	32	42.4	52	56	70	347.5	59.5
	40	48.3	52	56	70	347.5	59.5

1、技术参数 Technical Parameter

- ◆ 公称通径: DN20-DN25
Nominal Diameter: DN20-DN25
- ◆ 制冷剂: 适用于氨在内的各种不可燃制冷剂及无腐蚀性的气体、液体, 但要注意使用相应的密封材料, 可燃性碳氢化合物不推荐使用。
Refrigerant: Applicable to various non-flammable refrigerants such as ammonia and non-corrosive gases and liquids, but pay attention to the use of corresponding sealing materials. Flammable hydrocarbons are not recommended.
- ◆ 温度范围: $-46^{\circ}\text{C} \sim +65^{\circ}\text{C}$
Temperature Range $-46^{\circ}\text{C} \sim +65^{\circ}\text{C}$
- ◆ 压力范围: 最大工作压力 :28 bar g
Pressure Range: Max.Working pressure :28 bar g
- ◆ 电气参数: 微电子单刀双掷开关
Electrical Parameters: Microelectronic single pole double throw switch
250 V a.c / 10 A 30 V d.c / 5 A 有常开及常闭两种功能
250 V a.c / 10 A 30 V d.c / 5 A It has two functions: normally open and normally closed.
- ◆ DIN43650接线标准: PG11, 8-10mm
DIN43650 Cable Standard : PG11, 8-10mm
- ◆ 接线:1.5mm²(16AWG)3 + PE, IP65
Cable:1.5mm²(16AWG)3 + PE, IP65
- ◆ 外接法兰接口公称通径: DN20、DN25
Nominal Diameter Of External Flange Interface: DN20, DN25
- ◆ 回差: 12.5-50mm, 出厂默认50mm, 调节步长12.5mm
Float Level Difference:12.5- 50mm, Factory default 50mm, Adjust the step length12.5mm



2、说明 Instruction

LS50液位开关是以浮球为感应元件, 浮球在液体里时随液位浮力产生变化, 随着液位升降, 带动触头升降; 在开关机构上安装一个永久性磁铁, 当浮球随着液位升高时, 触头进入磁铁的磁场中, 然后磁铁把触头迅速闭合, 使开关动作。当液位下降时, 复位弹簧使磁铁缩回, 从而解除开关机构的动作, 实现了液位自动控制过程。

The LS50 uses a floating ball as the sensing element. When the floating ball is in the liquid, it changes with the liquid level buoyancy. With the liquid level rises and falls, the contact moves up and down; Install a permanent magnet on the switch mechanism. When the float rises with the liquid level, the contact enters the magnetic field of the magnet, and then the magnet closes the contact quickly to make the switch act. When the liquid level drops, the reset spring causes the magnet to retract, thereby releasing the action of the switch mechanism and realizing the automatic control process of the liquid level.

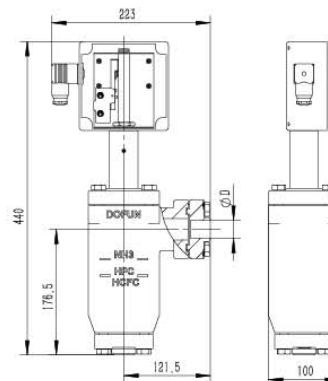

3、订货 Order Goods

- ◆ 需指定型号、接口通径尺寸
Please tell us the model and nominal diameter size of interface you want when ordering.
- ◆ 例: LS50-20表示DN20接口液位开关, 如不指定接口通径, 默认DN25
E.g.:LS50-20 it is means DN20 interface Liquid Switch, if the interface diameter is not specified, it will be defaulted is DN25.

型号 Model	通径 Nominal Diameter (DN)	ΦD	ΦD1
LS50	20	20	27
	25	25	33.7

1、技术参数 Technical Parameter

- ◆ 公称通径: DN15-DN150
Nominal Diameter: DN15-DN150
- ◆ 公称压力: 2.5MPa
Nominal Pressure: 2.5MPa
- ◆ 适用介质: R12,R22,R502,R134a,R404a,R507,R717等制冷剂。
Applicable Medium: R12,R22,R502,R134a,R404a,R507,R717 and other refrigerants.
- ◆ 适用温度: -46°C ~ +150°C
Applicable Temperature: -46 °C ~ + 150 °C
- ◆ 开启压差: 0.04bar
Opening Pressure Difference: 0.04bar



2、订货 Order Goods

- ◆ 需指定型号
Please tell us the model you want when ordering.
- ◆ 例: NRVD32
E.g.: NRVD32
表示DN32对夹止回阀
It is means DN32 Neck Flange Check Valve.

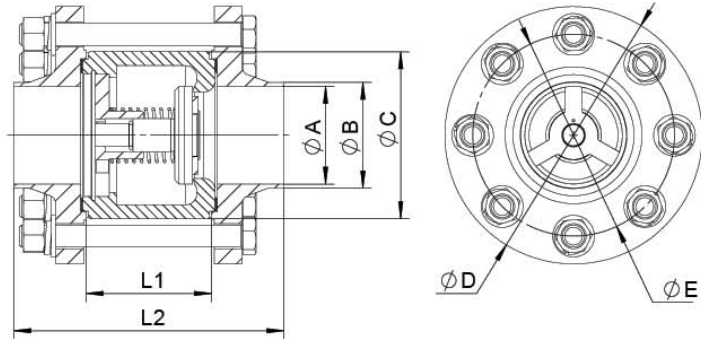

对夹止回阀 Neck Flange Check Valve									
型号 Model	通径 Nominal Diameter (DN)	尺寸 (mm) Size (mm)							
		φA	φB		φC	φD	φE	L1	L2
			A口	B口					
NRVD	15	15	21.3	21.3	68	115	85	65	145
	20	20	27	27	68	115	85	65	145
	25	25	33.7	32	68	115	85	65	145
	32	32	42.4	38	78	140	100	65	149
	40	40	48.3	45	88	150	110	70	160
	50	50	60.3	57	98	165	125	80	176
	65	65	76.1	76	120	185	145	90	192
	80	80	88.9	89	138	200	160	100	216
	100	100	114.5	108	160	235	190	114	244
	125	125	139.7	133	188	270	220	124	260
150	150	168.3	159	218	300	250	144	294	

1、技术参数 Technical parameters

- ◆ 公称口径：DN32-DN125
Nominal Diameter: DN32-DN125
- ◆ 公称压力：3.5MPa
Nominal Pressure: 3.5MPa
- ◆ 适用介质：R12,R22,R502,R134a,R404a,R507,R717, 等制冷剂。
Applicable Medium: R12, R22, R502, R134a, R404a, R507, R717, and other refrigerants.
- ◆ 适用温度：-46°C ~ +150°C
Applicable Temperature: -46°C ~ +150°C
- ◆ 滤网类型：SF-100 纸芯、H-100 干燥芯、F-100 不锈钢单层网芯（38 目、72 目、100 目、150 目）
Filter Type: SF-100 paper core; H-100 dry core; F-100Stainless steel single-layer mesh core (38 mesh, 72 mesh,100 mesh, 150 mesh)

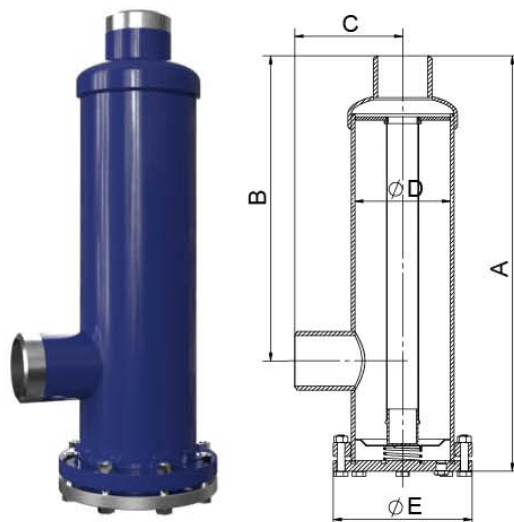

2、说明 Instruction

滤芯类型和数量可更换，适合更多的工况，可有效去除系统内部杂质、水分，从而更有效保护压缩机，并延长其使用寿命。

The type and number of filter elements can be replaced, suitable for more working conditions, and can effectively remove impurities and moisture inside the system, thereby protecting the compressor more effectively and prolonging its service life.

3、订货 Order Goods

- ◆ 需指定型号、滤芯类型，参考表格
Need to specify the model, filter type, refer to the table

滤网式筒式过滤器（100 型）Strainer Cartridge Filter (Model 100)								
型号 Model	芯数 No.of cores	对焊接口 Butt Welding		外形尺寸 Dimensions				
		(inch)	(mm)	A	B	C	D	E
DCA-10011	1	1-3/8	Φ41×3	296	204	116	152	196
DCA-10013	1	1-5/8	Φ48×3	296	200	116		
DCA-10017	1	2-1/8	Φ61×3.5	305	203	126		
DCA-10021	1	2-5/8	Φ74×3.5	313	206	136		
DCA-10025	1	3-1/8	Φ88×4	310	194	136		
DCA-10034	1	3-7/8	Φ107×4	308	180	136		
DCA-10042	1	4-7/8	Φ132×4	316	179	136		
干燥式筒式过滤器（48 型）Dry Cartridge Filter (Model 48)								
型号 Model	芯数 No. of cores	ODS 接口铜管 ODS Interface Copper Pipe	对焊接口钢管 Butt Welded Steel Pipe	外形尺寸 Dimensions				
		(inch)	(mm)	A	B	C	D	E
DCA-48485	1	5/8--16/19		233	152	79	114	153
DCA-48487	1	7/8--22/25		238	157	84		
DCA-48489	1	1-1/8--29/32	Φ32×3	243	162	89		
DCA-4811	1	1-3/8--35/38	Φ41×Φ35	243	162	89		
DCA-4813	1	1-5/8--42/45	Φ48×Φ42	248	157	94		
DCA-4817	1	2-1/8--54/58	Φ61×Φ54	252	161	94		
DCA-4821	1		Φ74×Φ67	259	163	117		
DCA-4825	1		Φ88×Φ80	253	147	117		
根据需求选择产品类型、滤芯个数（最多 4 个） Select the product type and the number of filter elements according to the needs (up to 4pcs can be selected)								

1、技术参数 Technical Parameter

- ◆ 公称通径: DN6-DN10
Nominal Diameter: DN6-DN10
- ◆ 公称压力: 4.0MPa、6.3Mpa
Nominal Pressure: 4.0MPa,6.3Mpa
- ◆ 适用介质: R12,R22,R502,R134a,R404a,R507,R717,R744 等制冷剂。
Applicable Medium: R12, R22, R502, R134a, R404a, R507, R717, R744 and other refrigerants.
- ◆ 适用温度: -46°C ~ +150°C
Applicable Temperature: -46 °C ~ + 150 °C

2、订货 Order Goods

- ◆ 需指定型号、结构形式、公称压力, 螺纹连接时还需明确螺纹规格和连接方式
Please tell us the model,the structural type, nominal pressure, and thread connection type when ordering. and thread connection also need to specify the thread specification and connection method.
- ◆ 例: DN6-A 表示 DN6 角式截止阀 公称压力 4.0MPa
E.g: DN6-A ,It is means DN6 Angle Type Stop Valve, Nominal Pressure is 4.0 MPa.
- ◆ DN6-HA 表示 DN6 角式截止阀 公称压力 6.3MPa 当不指定公称压力时, 默认状态 4.0MPa
DN6-HA ,It is means DN6 Angle Type Stop Valve,Nominal Pressure is 6.3 MPa.When the nominal pressure is not specified, its default state is 4.0MPa.

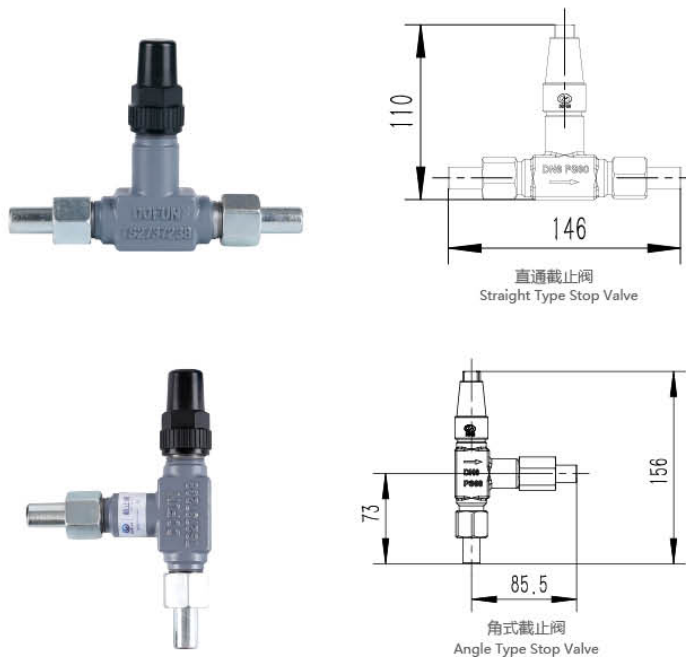

按照需要配置 DN6、DN10 接头, 角式配置可以根据需求加工不同的中心尺寸, 图示为默认配置尺寸
According to the need to configure DN6, DN10 joints, angle configuration can be processed according to different center sizes, the diagram shows default configuration size.

螺纹连接系列压力表阀门螺纹规格表 Thread connection series pressure gauge valve thread specification table			
序号 NO.	进口尺寸 Inlet Size	出口尺寸 Outlet Size	备注 Remark
SVS(A)-01	M20×1.5	M20×1.5	外螺纹 external thread

1、技术参数 Technical Parameter

- ◆ 公称通径: DN6-DN10
Nominal Diameter: DN6-DN10
- ◆ 公称压力: 4.0MPa、6.3MPa
Nominal Pressure: 4.0MPa,6.3MPa
- ◆ 适用介质: R12,R22,R502,R134a,R404a,R507,R717,R744 等制冷剂。
Applicable Medium: R12, R22, R502, R134a, R404a, R507, R717, R74 and other refrigerants.
- ◆ 适用温度: -46℃ ~ +150℃
Applicable Temperature: -46 °C ~ + 150 °C

2、订货 Order Goods

- ◆ 订货需指定型号、结构形式、公称压力
Please tell us the model ,structural type and nominal pressure you want when ordering.
- ◆ 例: PGV10-A 表示 DN10 角式压力表阀, 公称压力 4.0MPa
E.g:PGV10-A It is means DN10 Angle Type Pressure Gauge Valve,Nominal Pressure is 4.0MPa.
PGV10-S 表示 DN10 直通压力表阀, 公称压力 4.0MPa
PGV10-S It is means DN10 Straight Type Pressure Gauge Valve,Nominal Pressure is 4.0MPa.
PGV10-HS 表示 DN10 直通压力表阀, 公称压力 6.3MPa
PGV10-HS It is means DN10 Straight Type Pressure Gauge Valve,Nominal Pressure is 6.3MPa.
压力表阀接压力表螺母默认 M20×1.5, 左旋, 需要其它连接尺寸时需指明
The nut of the Pressure Gauge Valve connected to the pressure gauge defaults to M20×1.5, left-handed, and it should be specified when other connection dimensions are required.

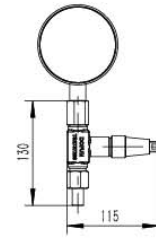

直通压力表阀

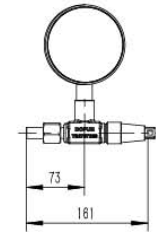

角式压力表阀

按照需要配置DN6、DN10接头, 角式配置可以根据需求加工不同的中心尺寸, 图示为默认配置尺寸

According to the need to configure DN6, DN10 joints, angle configuration can be processed according to different center sizes, the diagram shows default configuration size.

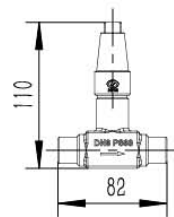

直通螺纹连接
Straight Type
Threaded connection

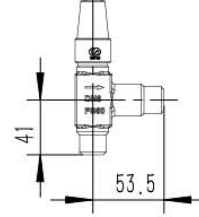

角式螺纹连接
Angle Type
Threaded connection

螺纹连接系列压力表阀门螺纹规格表 Thread Specification Table Of Thread Connection Pressure Gauge Valve			
型号 Model	进口尺寸 Inlet Size	出口尺寸 Inlet Size	备注 Remark
PGV(S/A)-01	M20×1.5	M20×1.5	外螺纹
PGV(S/A)-02	NPT 1/4	NPT 1/4	进口外螺纹, 出口内螺纹
PGV(S/A)-03	NPT 3/8	NPT 3/8	
PGV(S/A)-04	NPT 1/2	NPT 1/2	
PGV(S/A)-05	MPT 1/4	FPT 1/4	进口外螺纹 出口内螺纹 55°密封 管螺纹
PGV(S/A)-06	MPT 3/8	FPT 3/8	
PGV(S/A)-07	MPT 1/2	FPT 1/2	

直通/角式配置可以根据需求加工不同的中心尺寸, 图示默认配置尺寸。
The straight/angle configuration can process different center sizes according to requirements, and the diagram is default configuration size.



直通螺纹连接
Straight Type
Threaded connection



角式螺纹连接
Angle Type
Threaded connection

1、技术参数 Technical Parameter

- ◆ 公称进口口径: DSV1 DN25 DSV2 DN20、DN25、DN32
Nominal Inlet Diameter: DSV1 DN25 DSV2 DN20、DN25、DN32
- ◆ 出口螺纹: DSV1 NPT 3/4 DSV2 NPT 3/4、NPT 1 1/4
Thread Of Outlet: DSV1 NPT 3/4 DSV2 NPT 3/4、NPT 1 1/4
- ◆ 公称压力: 4.0MPa
Nominal Pressure: 4.0MPa
- ◆ 适用介质: R12,R22,R502,R134a,R404a,R507,R717,R744等制冷剂。
Applicable Medium:R12,R22,R502,R134a,R404a,R507,R717,R744 and other refrigerants.
- ◆ 适用温度: -46°C~+150°C
Applicable Temperature: -46 °C ~ + 150 °C



2、说明 Instruction

DSV三通截止阀主要用于连接两个安全阀，旋转阀杆可以两个安全阀之间切换，方便维护。

The DSV is mainly used to connect two safety valves, and the rotating stem can be switched between the two safety valves, which is convenient for maintenance.

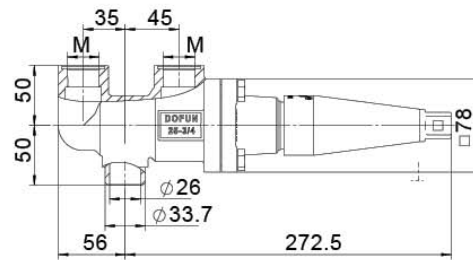

DSV1

3、订货 Order Goods

- ◆ 需指定型号、公称进口口径、出口螺纹尺寸
Please tell us the model,nominal inlet diameter, outlet thread size when ordering.
- ◆ 例: DSV2-25-3/4 表示进口口径DN25，出口NPT 3/4螺纹的DSV2三通截止阀
E.g.: DSV2-25-3/4 It is means DSV2 Double Stop Valve with inlet nominal diameter DN25,outlet thread is NPT3/4 thread .

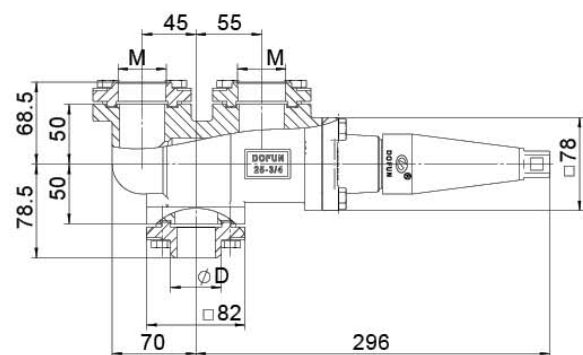

DSV2、DSV4

三通截止阀 Double Stop Valve		
型号 Model	出口螺纹尺寸 Outlet Thread size(M)	ΦD
DSV1-25	NPT3/4	33.7
DSV2-20	NPT3/4	27
DSV2-25	NPT3/4	33.7
DSV2-32	NPT3/4	42.4
DSV4-25	NPT 1 1/4	33.7
DSV4-32	NPT 1 1/4	42.4

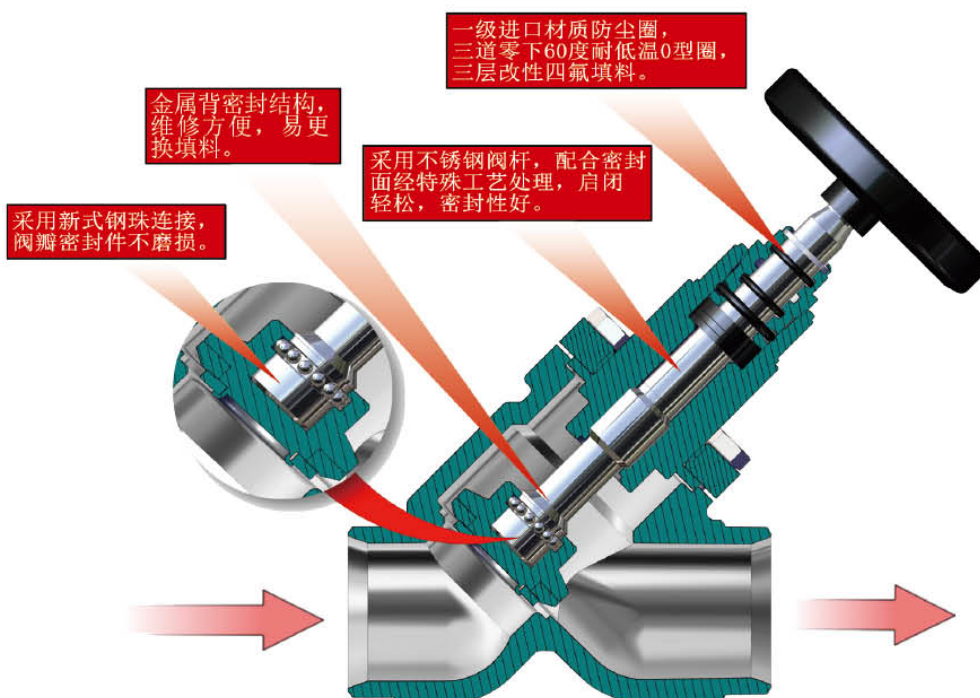

- 1、整体阀门由低温合金钢精铸或精锻而成，Y型结构，流体阻力小，不产生热量和涡流，不存液，减少制冷剂的加注量，不产生液爆和闪发气体。
- 2、六级密封结构，全部采用进口材料，完全杜绝泄露的发生，六级保护，安全可靠。
- 3、304不锈钢阀杆高耐腐蚀性永不生锈，表面经纳米技术处理（国家专利），提高表面硬度的同时，也使光洁度Ra值 ≤ 0.03 ，近乎无摩擦，任何情况下都能实现手轮启闭（无需扳手），正常启闭5000次无泄漏，极大提高使用寿命和安全性。
- 4、高强度压铸铝阀帽，轻便不锈，铝阀帽上拥有两个不同尺寸的内四方（国家专利），实现不同型号阀门的启闭功能。
- 5、先进的模块化设计，实现同一个阀体安装不同功能组件，实现不同功能，方便快捷。
- 6、加长结构（国家专利），焊接时不需要拆卸（阀门上每个螺栓都有固定的扭力，有效避免拆卸后按照扭力不合理产生泄露的可能），有效防止焊接热量损坏密封填料。
- 7、新型阀体密封结构（国家专利），保证阀门在任何位置都能有效关闭，极大提高安全性。

- 1.The valve is made through low-temperature alloy precision casting or forging, with Y-shaped structure which can reduce the flow resistance, avoid the calorification, eddy and effusion, decrease the supplement of refrigerant, and meanwhile produce no liquid explosion or flash gas.
- 2.The six-level sealing structure uses imported materials and can thoroughly avoid leakage. Six levels of protection makes the structure more safe and reliable.
- 3.The valve rod is made of 304 stainless steel which can never be rusted. The surface is NANO processed (national patent) which has increased the surface hardness; meanwhile, the Ra value of surface finish is no more than 0.03 and the friction is almost zero. Therefore, under all cases, it can be opened and closed with the pilot wheel (no need to use any wrench). It has a testing record which is no leakage after 5000 times of operating, thus greatly enhancing the service life and safety.
4. High strength die-cast Aluminum cap of valve is used which is lightweight and stainless. Two different sizes of Quadrates (national patent) are on the cap to realize the operation of different types of valve rods
5. Advanced modular design makes it possible to assemble different functions of components on the same valve, which is quite convenient and quick
- 6.Its lengthened structure (national patent) never requires disassembling when welding (each bolt on the valve has fixed torque, effectively avoiding the leakage due to the unreasonable installation of torque when reassembling), which can effectively protect seal fillings from welding heat.
7. New type of seal structure (national patent) ensures the valve can be effectively closed at any position, greatly improving the safety.

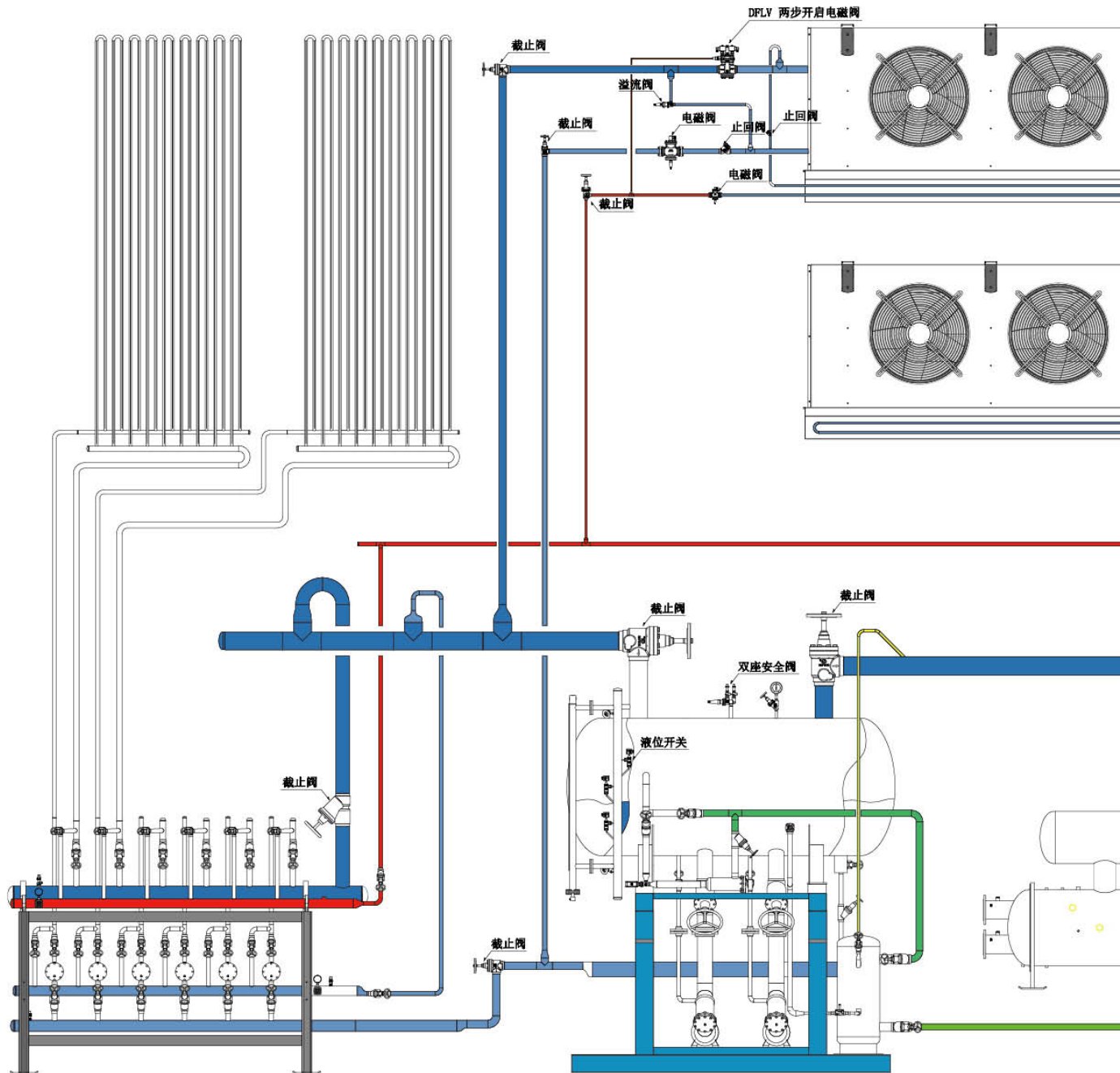

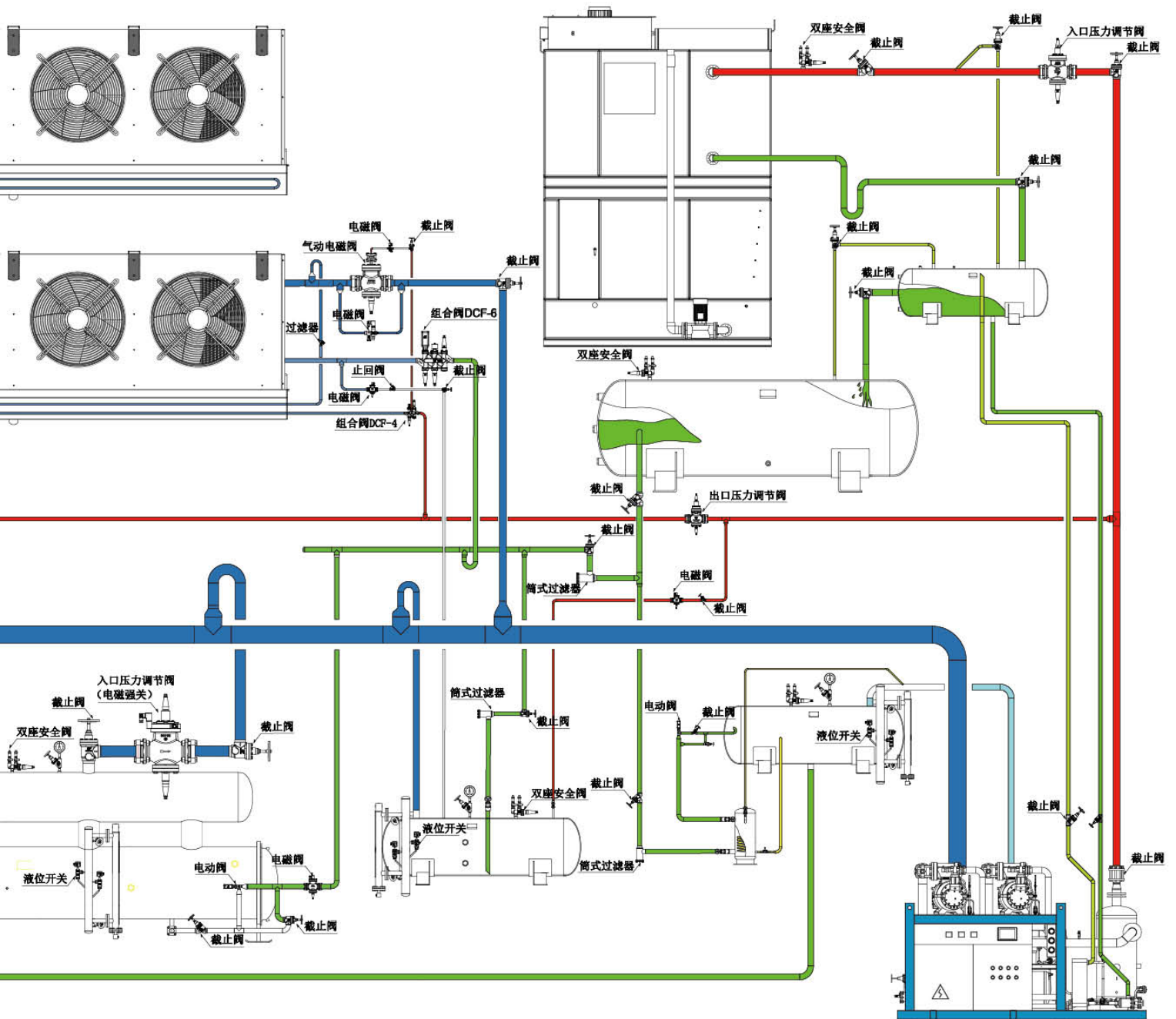









启于己心

From the dream

止于至善

To the world

Dofun

Dofun

山东东润制冷科技有限公司
Shandong DoFun Refrigeration Technology Co., Ltd

Australia Exclusive Agent:
Excel Industrial Services Pty Ltd

Address: 16 Prince William Drive, Seven Hills NSW 2147 Australia
Phone: +61 2 9674 7477
Email: Valve@excelindustrialservices.com

Dofun[®] 将尽最大努力确保出版物中所有细节在付印时的正确性，但不构成任何的承诺和保证。我们将持之以恒地追求进步，为此我们保留不经过通知而对产品技术规格和设计进行改进的权利。样本中图片，未经同意，不得转载。

Dofun[®] 品牌策划部设计。版权所有。